

DEPARTMENT OF THE ARMY TECHNICAL MANUAL

---

TECHNICAL MANUAL

ORGANIZATIONAL, DIRECT SUPPORT, AND GENERAL SUPPORT

MAINTENANCE MANUAL

(INCLUDING REPAIR PARTS AND SPECIAL TOOLS LIST

FOR ORGANIZATIONAL, DIRECT SUPPORT, GENERAL

SUPPORT, AND DEPOT MAINTENANCE)

COMPRESSOR ASSEMBLY, RECIPROCATING AIR,

6 CFM, 3000 PSI (WALTER KIDDE PART NUMBER

894780) FSN 4310-228-0766

COMPONENT OF M60A2 TANK

---

HEADQUARTERS , DEPARTMENT OF THE ARMY

MARCH 1973

## **WARNING**

**Do not attempt to remove or disassemble pressurized equipment. Stop all equipment operation, vent all pressure to atmosphere prior to performing work in order to prevent injury to personnel and damage to equipment. Remove fan spring (18, fig C-3) with extreme care. The fan spring is spring loaded and will recoil suddenly when removed causing possible injury to personnel.**

**ORGANIZATIONAL, DIRECT SUPPORT,  
AND GENERAL SUPPORT  
MAINTENANCE MANUAL**

**(INCLUDING REPAIR PARTS AND SPECIAL TOOLS LIST  
FOR ORGANIZATIONAL, DIRECT SUPPORT,  
GENERAL SUPPORT AND DEPOT MAINTENANCE)**

**COMPRESSOR ASSEMBLY, RECIPROCATING AIR,**

**6 CFM, 3000 PSI**

**(WALTER KIDDE PART NUMBER 894780)**

**FSN 4310-228-0766**

**(COMPONENT OF M60A2 TANK)**

**Current as of 24 January 1973**

		Paragraph	Page
CHAPTER	1.	INTRODUCTION	
Section	I.	General .....	1-1
	II.	Description and data .....	1-4
CHAPTER	2.	ORGANIZATIONAL MAINTENANCE INSTRUCTIONS	
Section	I.	Service upon receipt of materiel .....	2-1
	II.	Repair parts and special tools .....	2-3
	III.	Preventive maintenance checks and services .....	2-5
	IV.	Troubleshooting (organizational) .....	2-8
	V.	Maintenance of compressor assembly .....	2-9
CHAPTER	3.	DIRECT SUPPORT AND GENERAL SUPPORT MAINTENANCE INSTRUCTIONS	
Section	I.	Repair parts and special tools .....	3-1
	II.	Troubleshooting (direct support) .....	3-3
	III.	Removal and installation of major components .....	3-4
APPENDIX	A.	REFERENCES	
	B.	MAINTENANCE ALLOCATION CHART	
Section	I.	Introduction .....	B-1
	II.	Maintenance allocation chart .....	B-3
	III.	Special tool and special test equipment requirements .....	B-4
Appendix	C.	ORGANIZATIONAL, DIRECT SUPPORT, AND GENERAL SUPPORT MAINTENANCE REPAIR PARTS AND SPECIAL TOOLS LIST (INCLUDING DEPOT MAINTENANCE REPAIR PARTS AND SPECIAL TOOLS)	
Section	I.	Introduction .....	C-1
	II.	Repair parts for organizational maintenance .....	C-4
	III.	Repair parts for direct support, general support, and depot maintenance .....	C-5
	IV.	Special tools list .....	C-19
	V.	Federal stock number and reference number index .....	C-20
INDEX			I-1

## CHAPTER 1

## INTRODUCTION

## SECTION I. GENERAL

## 1-1. Scope

a. This manual is prepared for the information and guidance of organizational, direct support, and general support personnel responsible for maintenance and repair of the 3,000 psi 6 cfm Compressor Assembly, Part Number 894780. It is complementary to TM 9-2350-232-20 and TM 92350-232-34.

b. Appendix A lists references pertaining to the air compressor.

c. Appendix B contains the maintenance allocation chart.

d. Appendix C lists repair parts and special tools through depot maintenance level.

## 1-2. Forms and Records

Maintenance forms, records, and reports which are to be used by maintenance personnel at all maintenance levels are listed in and prescribed by TM 38-750.

## 1-3. Reporting of Errors

Report of errors, omissions, and recommendations for improving this publication by the individual user is encouraged. Reports should be submitted on DA Form 2028, Recommended Changes to Publications, and forwarded direct to: Commanding Officer, U. S. Army Mobility Equipment Command. ATTN: AMSME-MPP. 4300 Goodfellow Blvd., St. Louis, Mo. 63166.

## Section II. DESCRIPTION AND DATA

## 1-4. Description

a. *General.* The compressor assembly (fig C-1) is a component of the closed breech scavenge system used on the M60A2 tank. The system provides compressed air for cleaning the gun / launcher of any ignited powder or powder bag particles prior to opening the breech.

**NOTE**

**For purposes of orientation, the compressor mounting adapter end will be called the rear and the fan end will be called the front. The term left or right as used will be referenced to the compressor as viewed from the front looking to the rear.**

b. *Theory of Operation.* In a pneumatic system, changing the value of a given quantity of air (under ambient conditions) results in a change in pressure, temperature, and vapor content characteristics. The change in pressure is directly proportional to the change in volume. The change in temperature is directly related to the change in pressure. The vapor content of a given volume of air is directly dependent on the temperature and inversely dependent on the pressure. The compressor assembly is part of a pneumatic system. The function of the compressor in the pneumatic system is to change the air volume. Air volume change in a pneumatic system can be positive (pressurized) or

negative (evacuated) dependent upon whether the pneumatic system is located upstream or downstream of the compressor. The compressor in this manual is used to pressurize the pneumatic system.

c. *Operation.* The compressor compresses ambient air to the operating pressure of 3,000 psi with a flow rate of 6.0 scfm. In order to supply this compressed air, the compressor drive rotates the compressor in a clockwise direction (facing fan) at a rated speed of 4,250 to 4,450 rpm. The compressed air flow from one compression stage to the next passes through relief valves and intercoolers up to the fourth compressor stage. From the fourth stage, the compressed air flow (fig 1-1) is directed through an air flow restrictor fitting to a high pressure relief valve and to the aftercooler and compressor outlet (discharge) fitting. From the compressor outlet (discharge) fitting, the compressed air flow is directed to the air processing assemblies in the pneumatic system, then to the using equipment. The hot, high pressure compressed air, when passing through the finned intercoolers and aftercoolers, loses the heat of compression to the ambient air. To increase the heat transfer rate, the compressor fan forces the ambient air past the finned cooler surfaces. Excessive interstage or pneumatic system pressure is

relieved to atmosphere through the relief valves. Lubrication of the compressor (fig 1-29) is accomplished by the gerotor which is installed within the crankcase adjacent to the fan. the gerotor draws filtered oil from the crankcase oil sump and discharges the oil through the crankshaft to

components to be lubricated. A spring loaded, oil bypass, relief valve is located in the crankcase permitting the oil to bypass from the gerotor outlet to the gerotor inlet passage in case of oil over-pressurization.

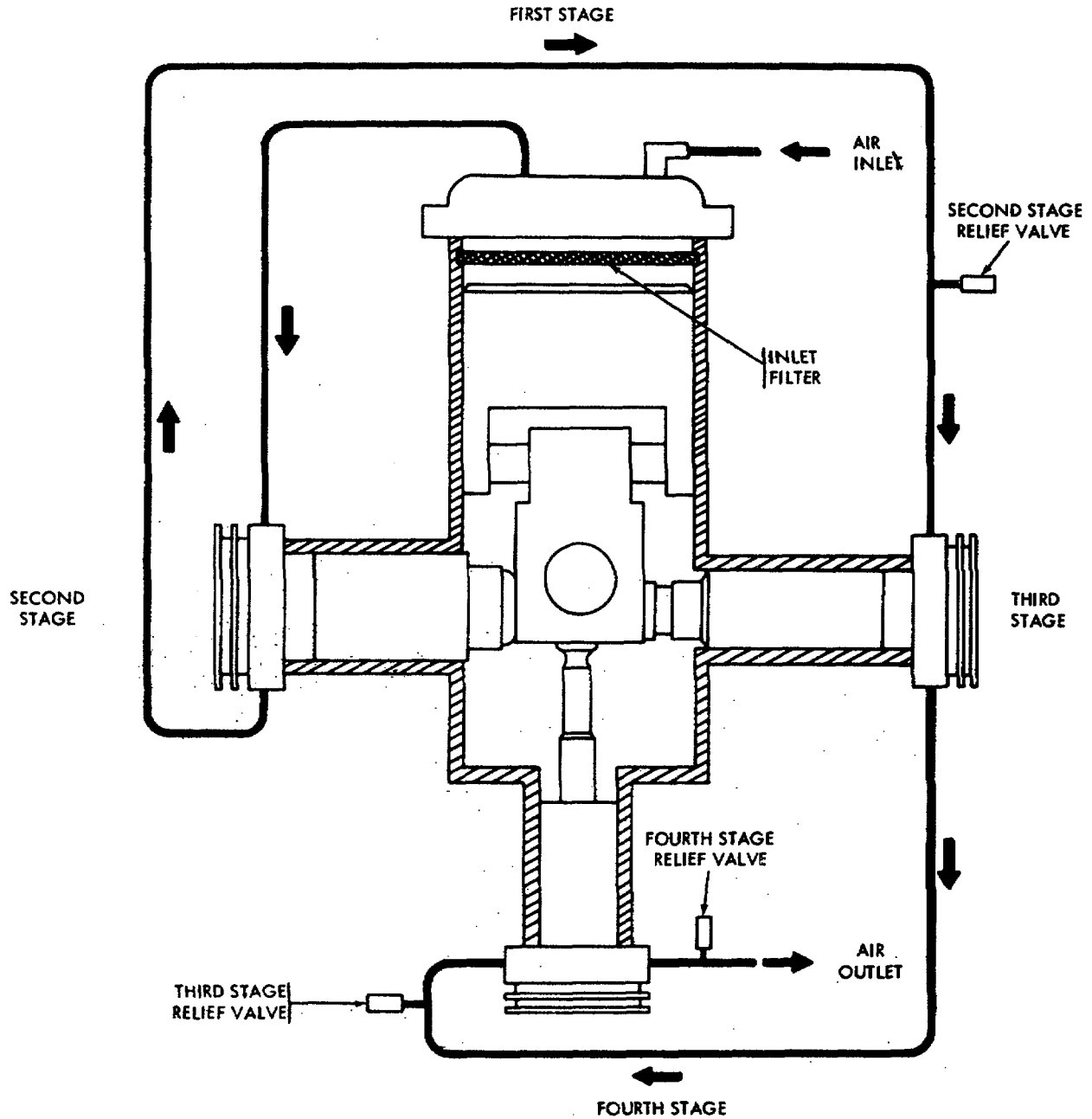

ME 4310-340-24/1-1

Figure 1-1. Compressed air flow-schematic.

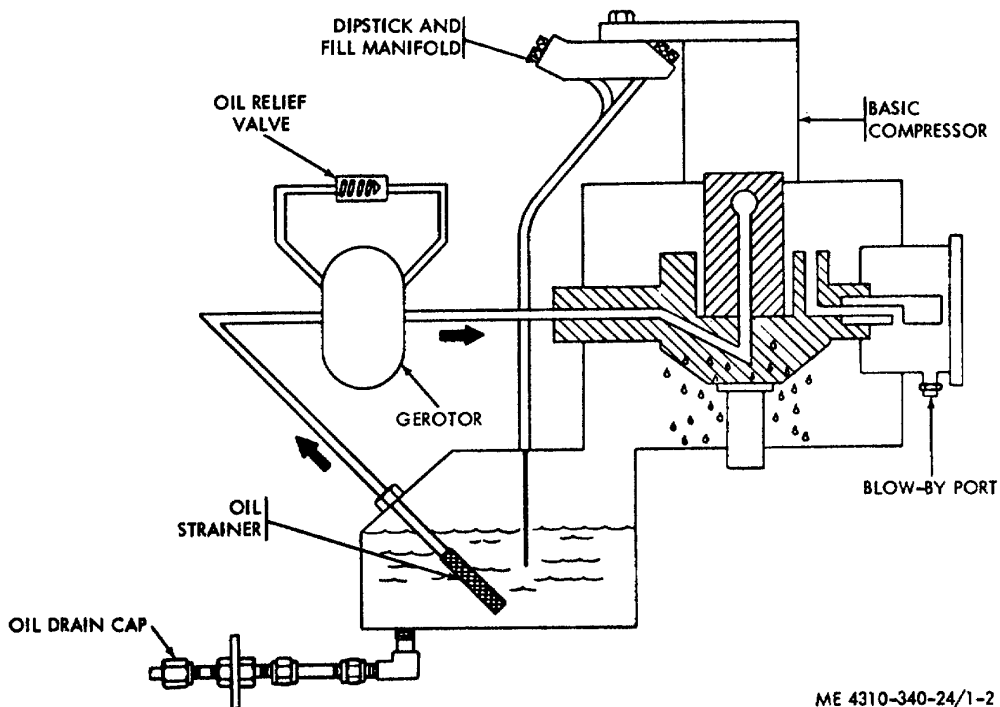

Figure 1-2. Compressor lubrication system-schematic.

1-5. Tabulated Data

a. General

(1) Compressor assembly.

Length, overall ..... 9.10 in. max  
 Width, overall ..... 12.25 in. max  
 Height, overall ..... 13.50 in. max  
 Weight, dry ..... 24.4 lb

(2) Compressor.

Type ..... Radial, reciprocating  
 Stages ..... 4  
 Cylinders ..... 4  
 Rotation (facing fan end) ..... Clockwise  
 Speed ..... 4450 rpm, max  
 Operating pressure (air) ..... 3000 ± 100 psi  
 Capacity ..... 6.0 scfm  
 Temperature range ..... -65° F to 260° F  
 Lubrication ..... Forced feed  
 Lubricating oil ..... MIL-L-236)99  
 Oil capacity ..... 1-1/4 pt (20oz)  
 Stage operating pressure:  
   1st stage ..... 50 to 64 psig  
   2nd stage ..... 245 to 295 psig  
   3rd stage ..... 820 to 1020psig  
   4th stage ..... 3000 psig  
 Filter ..... 40 micron

(3) Second stage relief valve.

Type ..... Spring loaded check

Flow capacity ..... 6 scfm  
 Full flow pressure ..... 550 psig, max

(4) Third stage relief valve.

Type ..... Spring loaded check  
 Flow capacity ..... 6 scfm  
 Full flow pressure ..... 1400 psig, max

(5) Fourth stage relief valve.

Type ..... Spring loaded piston

Flow capacity ..... 6 scfm  
 Full flow pressure ..... 4500 ' + 10() psig

(6) Fan 5 blade, spring loaded

b. Recommended Wrench Torque.

Component	Torque (Pound inches)
Screw, fan	125
Nut, intercooler 1st	270-300
Nut, intercooler 2nd	135-150
Nut, intercooler 3rd	135-150
Nut, aftercooler	135-150
Nut, oil tube	135-150
Screw, discharge bracket	60-65
Screw, 4th stage head	60-65
Screw, 3rd stage head	30-4)
Screw, 2nd stage head	60-65
Screw, 1st stage head	30-35
Nut, cushion clamp	20-25

Screw, fan guard .....	35-40
Screw, fan guard bracket .....	40-65
Screw, cooler clamp.....	15-20
Union, oil inlet.....	50

**1-6. Identification Plates**

**The compressor has one identification plate located on left side of crankcase sump.**

## CHAPTER 2

## ORGANIZATIONAL MAINTENANCE INSTRUCTIONS

## Section I. SERVICE UPON RECEIPT OF MATERIEL

**2-1. General**

This section contains information pertaining to services to be performed on the compressor (installed in vehicle) upon receipt of a new or rebuilt vehicle.

Record for Shipment, Storage, and Issue of Vehicles and Spare Engines tag (I)1) Form 1: )3which should be in the driver's compartment attached to the steering control or transmission shift lever. Assure that all instructions listed are followed.

**2-2. Inspecting and Servicing Instructions**

a. Read the Processing and Deprocessing

b. Perform preventive maintenance checks and services listed in Section III.

## Section II. REPAIR PARTS AND SPECIAL TOOLS

**2-3. Repair Parts**

Repair parts are listed in Appendix C of this manual.

**2-4. Special Tools**

No special tools are required to perform organizational maintenance.

## Section III. PREVENTIVE MAINTENANCE CHECKS AND SERVICES

**2-5. General**

This section contains procedures for preventive maintenance checks and services performed by organizational maintenance personnel at 10() rounds fired or quarterly, whichever occurs first. Operation under adverse conditions will make servicing a more frequent requirement. The interval will be reduced whenever conditions indicate the need.

c. *Service.* Servicing consists of performing operations such as cleaning oil strainer and changing oil.

d. *Tighten.* All tightening operations should be performed with sufficient wrench torque to tighten the unit according to specified torque (para 1-5). Do not overtighten, as this may strip threads or cause distortions.

**2-6. Maintenance Functions**

Organizational maintenance functions are defined as follows:

a. *Adjust.* Make all necessary adjustments authorized by this manual or applicable technical bulletins.

b. *Clean.* Clean the item to remove old lubricant and other foreign matter.

e. *Repair.* Repair consists of restoring an item to serviceable condition.

**2-7. Procedures**

Specific procedures are listed in table 2-1.

**NOTE**

**Liquid soap or a soap and water mixture may be used to detect leaks on pressure, lines and fittings.**



Table 2-1. Preventive Maintenance Checks and Services

Organizational Maintenance

Quarterly Schedule

Sequence number	Item to be inspected	Procedure	Paragraph Reference
<b>BEFORE OPERATING COMPRESSOR</b>			
1	Lubricating oil.	Check level. Add or change oil as required.	LO 9-2350-232-12
2	Oil level dipstick.	Check dipstick and preformed packing for damage. Replace damaged parts.	(para 2-13)
3	Screws, nuts, brackets, and clamps	Check for looseness. Tighten as required.	(para 1-5)
4	Coolers	Check for bent fins and loose connections. Straighten fins and tighten connections as required.	(para 1-15)
<b>COMPRESSOR OPERATING</b>			
5	Oil tubes, fittings, and gaskets.	Check for leaks. If leaks are found, stop compressor and tighten defective tube or fitting as required. Operate compressor and recheck leak. If leak continues and cannot be stopped, stop compressor and notify direct support maintenance.	(para 1-5)
6	Compressor assembly	Listen for any unusual noises. If unusual noises are heard, locate and correct cause. If cause cannot be corrected at organizational level, stop compressor and notify direct support maintenance.	
7	Compressor assembly	Check for vibration, overheating, or smoking. If overheating, vibrations, or smoking exist, stop compressor and notify direct support maintenance.	
8	Compressor assembly	Check for proper operation. If air supply is insufficient, and the compressor is at fault, stop compressor and notify direct support maintenance.	

**Section IV. TROUBLESHOOTING (ORGANIZATIONAL)**

**2-8. General**

a. This section contains troubleshooting information for locating and correcting some of the troubles that may develop in the compressor. The information is arranged to provide the mechanic with a flexible and logical step-by-step method of troubleshooting. Once a malfunction is recognized, the mechanic is guided in solving the maintenance problem by the use of troubleshooting routines or by the combined use of troubleshooting routines and supporting information.

b. This manual cannot cover all possible troubles which may occur under the many operating conditions. If a specific trouble, test, and remedy is not covered, proceed to isolate the system in which the trouble occurs and then locate the defective component. Standard automotive theories

and principles of operation apply in troubleshooting the equipment. Use all senses and methods to observe and to locate troubles. To obtain the maximum number of observed symptoms of trouble, question the vehicle crew about the conditions under which the symptoms occurred. The greater the number of symptoms of troubles that can be evaluated, and the more detailed the knowledge of the conditions under which they occurred, the easier it will be to isolate the defect.

c. When troubleshooting, it is important to note that the compressor is a part of a system which consists of associated components and a compressor drive. Trouble in the system may be caused by other components and not the compressor. See TM 9-2350-232-20-2 for troubleshooting all components of the system except the compressor.

**Chart 2-1. Troubleshooting-Organizational**

<b>Malfunction</b>	<b>Probable cause</b>	<b>Corrective Action</b>
1. Compressor overheats	a. Dirty coolers. b. Air circulation obstructed. c. Low oil level. d. Defective compressor	a. Clean coolers. b. Remove obstruction. c. Add oil to full mark on dipstick (LO 9-2350-232-12) d. Notify direct support maintenance
2. Excessive oil consumption	a. Leaking tube or fitting b. Defective compressor	a. Check tubes and fittings for leaks. Tighten as required (para 1-.)I. If leak cannot be stopped. notify direct support maintenance. b. Notify direct support maintenance.
3. Relief valve activated	a. Defective relief valve. b. Defective compressor.	a. Notify direct support maintenance. b. Notify direct support maintenance.
4. Excessive vibration	a. Loose compressor screws b. Defective compressor	a. Tighten screws (TM 9-2350-232-20) . b. Notify direct support maintenance.
5. Compressor will not turn	a. Defective spline. b. Defective compressor internal components	a. Notify direct support maintenance. b. Notify direct support maintenance.
6. Insufficient air pressure	a. Loose cooler connection. b. Defective compressor.	a. Tighten connection. b. Notify direct support maintenance.

**Section V. MAINTENANCE OF COMPRESSOR ASSEMBLY**

**2-9. General**

The information in this section provides organizational maintenance personnel with the necessary information to maintain those com-

ponents allocated to organizational maintenance. During installation of pipe threaded fittings use teflon tape per MIL-T-27730 on fitting threads. Lubricate threads and packings with oil per MIL-

L-23699. Torque components as specified in the instructions and paragraph 1-5.

**2-10 . Oil Drain Tube Cap**

*a. Removal (fig. C-3).*

- (1) Drain oil from compressor.
- (2) Disconnect chain (35) from cap (34).

*b. Installation*

- (1) Install cap on drain tube union (37).
- (2) Connect chain (35) to cap (34).
- (3) Fill sump with oil (LO 9-2350-232-12).

**2-11. Oil Drain Tube Cap Chain**

*a. Removal (fig. C-3).* Disconnect chain (35) from cap (34) and bracket (36).

*b. Installation.* Connect chain (35) (approximately 4-inches long) to cap (34) and bracket (36).

**2-12. Air Inlet Fitting**

*a. Removal (fig C-6).*

- (1) Loosen clamps securing inlet tube hose and slide hose from fitting (1).
- (2) Unscrew fitting from compressor head.

*b. Installation*

(1) Apply teflon tape per MIL-T-27730 to inlet fittings threads.

(2) Install inlet fitting (1) to compressor head. Tighten securely with fitting aligned with inlet tube.

(3) Install inlet tube hose on fitting (1) and secure with two clamps.

**2-13. Oil Level Dipstick and Packing**

*a. Removal (fig. C-10).*

(1) Unscrew dipstick (34) from manifold (39) and remove dipstick from manifold.

(2) Remove, performed packing (35) from dipstick.

*b. Installation*

(1) Install preformed packing (35) on dipstick (34).

(2) Insert dipstick into manifold (39) and tighten securely.

**2-14. Oil Fill Plug and Packing**

*a. Removal (fig C-10).*

(1) Unscrew plug (38) from manifold (39).

(2) Remove preformed packing (35) from plug.

*b. Installation.*

(1) Install preformed packing (35) on plug 138).

(2) Install plug (38) in manifold (39) and tighten securely.

CHAPTER 3

DIRECT SUPPORT AND GENERAL SUPPORT

MAINTENANCE INSTRUCTIONS

Section I. REPAIR PARTS AND SPECIAL TOOLS

**3-1. Repair Parts**

Repair parts are listed in Appendix C of this manual.

**3-2. Special Tools**

Special tools are listed in table 3-1 and listed and illustrated in Appendix C.

Table 3-1. Special Tools

Item	FSN or Part No.	Reference		Use
		Figure	Paragraph	
Fixture, fan assembly	890854	C-12 (15)	3-6	Install fan spring in fan. Assemble rear oil seal.
Tool, oil seal insertion	804419	C-12 (5)	3-26	

Section II. TROUBLESHOOTING (DIRECT SUPPORT)

**3-3. General**

a. This section contains troubleshooting information and tests for locating and correcting some of the troubles that may develop in the compressor. The information is arranged to provide the mechanic with a flexible and logical step-by-step method of troubleshooting. Once a malfunction is recognized, the mechanic is guided in solving the maintenance problem by the use of troubleshooting routines or by the combined use of troubleshooting routines and supporting information.

b. This manual cannot cover all possible troubles which may occur under the many operating conditions. If a specific trouble, test, and remedy is not covered, proceed to isolate the system in which the trouble occurs and then locate the defective component. Standard automotive theories and principles of operation apply in

troubleshooting the equipment. Use all senses and methods to observe and to locate troubles. To obtain the maximum number of observed symptoms, of trouble, question the vehicle crew about the conditions under which the symptoms occurred. The greater the number of symptoms of troubles that can be evaluated, and the more detailed the knowledge of the conditions under which they occurred, the easier it will be to isolate the defect.

c. All troubleshooting procedures requiring operation of compressor must be performed with compressor installed in vehicle.

d. When troubleshooting, it is important to note that the compressor is a part of a system which consists of associated components and a compressor drive. Trouble in the system may be caused by other components and not the compressor. See TM 9-2350-232-34 for troubleshooting all components of the system except the compressor.

Chart 3-1. Troubleshooting-Direct Support

Malfunction	Probable Cause	Corrective Action
1. Compressor overheats.	<ul style="list-style-type: none"> <li>a. Defective fan spring.</li> <li>b. Defective fan.</li> <li>c. Defective compressor internal components</li> </ul>	<ul style="list-style-type: none"> <li>a. Replace fan spring (para 3-6).</li> <li>b. Replace fan (para : 3-6).</li> <li>c. Replace compressor (TM-9-2350-232-20-1).</li> </ul>
2. Relief valve activated (open).	<ul style="list-style-type: none"> <li>a. Defective cooler to next higher stage and/or defective aftercooler.</li> <li>b. Defective relief valve.</li> </ul>	<ul style="list-style-type: none"> <li>a. Replace defective cooler and/or aftercooler (para :3-8. 3-9. 3-10. 3-11. and 3-14).</li> <li>b. Test relief valve by replacement with a new valve (para 3-12. 3-1 and 3-17). Discard relief valve removed if defective.</li> </ul>
3. Excessive oil consumption.	<ul style="list-style-type: none"> <li>a. Defective oil seals and/or packings.</li> <li>b. Excessive worn internal components.</li> </ul>	<ul style="list-style-type: none"> <li>a. Replace defective seals and/or packings (para 3-26).</li> <li>b. Replace compressor (TM 9-2350-232-20-1).</li> </ul>
4. Excessive vibration.	<ul style="list-style-type: none"> <li>a. Defective fan.</li> <li>b. Defective compressor.</li> </ul>	<ul style="list-style-type: none"> <li>a. Replace fan (para 3-6).</li> <li>b. Replace compressor (TM 9-2350-232-20-1).</li> </ul>
5. Compressor	<ul style="list-style-type: none"> <li>a. Defective spline (input shaft).</li> <li>b. Defective compressor internal components.</li> </ul>	<ul style="list-style-type: none"> <li>a. Replace compressor (TM 9-2350-232-20-1).</li> <li>b. Replace compressor (TM 9-2350-232-20-1).</li> </ul>
6. Insufficient air pressure in system.	<ul style="list-style-type: none"> <li>a. Leaking cooler or cooler connection.</li> <li>b. Defective relief valve.</li> <li>c. Defective compressor.</li> </ul>	<ul style="list-style-type: none"> <li>a. Tighten connection or replace cooler as required (para 1-5, 3-8, 3-9, 3-10, 3-11 and 3-141).</li> <li>b. See item 2b.</li> <li>c. Replace compressor (TM 9-2350-232-20-1).</li> </ul>

**Section III. REMOVAL AND INSTALLATION OF MAJOR COMPONENTS**

**3-4. General**

The information this section provides direct and general support maintenance personnel with the necessary instructions to remove and install all compressor assembly major components and assemblies as allocated by the maintenance allocation chart. Removal and installation of a component or an assembly does not require the removal of all preceding components in the disassembly sequence. Remove only those items necessary to permit access to the defective components being removed. During installation of pipe threaded fittings use teflon tape. per MIL-T-27730 at threads and lubricate thread and packings with oil per M1L-L-23699., Torque components as specified in the assembly instructions and paragraph 1-5.

**WARNING**

**Do not attempt to remove or disassemble pressurized equipment. Stop all equipment operation, vent all pressure to atmosphere prior to performing work in order to prevent injury to personnel and damage to equipment.**

**CAUTION**

**Cap or plug all openings, after removal of components or subassemblies from compressor, in order to prevent entry of dirt into unit. Entry of dirt into unit can result in damage or malfunction of equipment.**

**3-5. Fan Guard**

*a. Removal (fig C-3).* Remove four screws (10), lockwashers (9), washers (8) and fan guard (7) from brackets (26).

*b. Installation.* Position fan guard (7) on brackets (26) with cutaway at bottom of compressor. Aline bracket screw holes between fan guard parallel traverse bars. Secure fan guard to brackets with four washers (8), lockwashers (9), and screws (10).

**3-6. Fan and Fan Spring**

**WARNING**

**Remove fan spring (18, fig C-3) with extreme care. The spring is spring loaded and will recoil suddenly when removed causing possible injury to personnel.**

**NOTE**

**It is not necessary to remove spring (18, fig. C-3) and spring lock (19) from fan if fan is being removed to gain access to other defective components. Remove spring and spring lock from fan only when necessary for replacement of spring or fan.**

*a. Removal (fig C-3).*

- (1) Remove fan guard (para 3-5).
- (2) Remove lockwire (32), five screws (11), five washers (12), hub cover (13), and seal (14).
- (3) Remove fan screw (15), thrust washer (16), and spring cover (17) from fan (21).
- (4) Grip fan spring (18) with a pair of needle nose pliers and pull spring from fan.
- (5) Remove spring lock (19) from fan.
- (6) Remove fan bushing (20), fan (21), and thrust washer (22) from crankshaft.

*b. Installation.*

- (1) Position thrust washer (22) on compressor crankshaft.
- (2) Using a suitable spring compressor, complete spring lock (19) and insert into fan hub.

**NOTE**

**Regardless of condition of fan spring 118) replace with a new spring.**

(3) Using fan assembly fixture (15, fig C-12), place fan spring into fixture guide and turn handle of fixture slowly tightening spring in guide. With spring right in guide, use pusher to gradually force spring into fan hub until spring snaps into place. If spring does not snap into place correctly, remove spring, discard and replace with a new spring.

(4) Position fan bushing (20), fan (21) with assembled parts and cover (17) on compressor crankshaft. Secure with thrust washer (16) and fan screw (5). Tighten fan screw to 125 lb-in.

(5) Position seal (14) and cover (13) on fan. Secure with five screws (11) and washers (2). Secure screws (11) with lockwire (32).

**3-7. Drain Tube Assembly***a. Removal (fig C-3).*

- (1) Remove two screws (31), nuts (28), and washers 1301 securing bracket (36) to clamps.
- (2) Disconnect tube (38) from elbow (39) and remove assembly from compressor. (3) Disassemble assembly as required using figure C-3 as a guide.
- (4) Remove elbow (39) from compressor oil sump.

*b. Installation***NOTE**

**Apply teflon tape to all pipe threads prior to assembly per MIL-T-27730.**

- (1) Install elbow (39) in compressor oil sump.

(2) Using figure C-3 as a guide, assemble drain tube assembly if disassembled during removal.

- (3) Connect tube (38) to elbow (39).

(4) Secure drain tube bracket (36) to clamps with two screws (31) nuts (28) and washers (30).

**3-8. Third Stage Cooler****NOTE**

**It is not necessary to remove fan when removing coolers individually. However, nuts (6 fig C-3) and cooler end nuts will become accessible if fan is removed (para 3-6).**

*a. Removal (fig C-3).*

- (1) Remove fan guard (para 3-5).
- (2) Remove two screws (31), nuts (28) and washers (30) securing oil drain tube bracket to clamps.
- (3) Loosen end nut of tube (38) at elbow (39) and move tube away from coolers. Tighten tube end nut if oil sump is not drained.
- (4) Remove eight cooler clamp screws (3), nuts (6), and 16 washers (4). Remove four cooler clamps (5).
- (5) Remove screw, nut, and washer securing third stage cooler clamp to after cooler clamp at relief valve end of third stage cooler (2).
- (6) Disconnect third stage cooler (2) from relief valve (27) and elbow (1). Remove cooler (2) from compressor.
- (7) Remove three cushion clamps from cooler if cooler is being replaced. Omit this step if cooler is being removed to gain access to other components.

*b. Installation*

- (1) Position third stage cooler (2) on fan guard brackets (26) and loosely connect cooler end nuts to elbow (1) and relief valve (2).
- (2) Position four cooler clamps (5) over coolers and secure to fan guard brackets (26) with eight screws (3), nuts (6) and 16 washers (40).
- (3) Tighten cooler end nuts to 135-150 lb-in.
- (4) Position cushion clamps. if removed, on cooler (2). Secure clamps to aftercooler clamp and oil drain tube bracket with three screws, nuts, and six washers.

**3-9. Second Stage Cooler***a. Removal.*

- (1) Remove third stage cooler (para 3-8).
- (2) Remove screw (6 fig C-4), nut (7), and two washers (5) from cushion clamps (4). Remove clamp from cooler (3).
- (3) Disconnect cooler (3) from relief valve (8) and elbow (19).
- (4) Remove screw (23), fig D-3, lockwasher (24), flat washer (25), and upper right fan guard bracket (26).

- (5) Remove cooler from compressor.

*b. Installation (fig C-4).*

(1) Position cooler (3) on fan guard brackets (26) and loosely connect cooler end nuts to elbow (9) and relief valve (8).

(2) Position clamp (4) on cooler (3) and secure to aftercooler clamp with screw (6), nut (7), and two washers (5).

(3) Install third stage cooler (para 3-8).

(4) Tighten second stage cooler end nuts to 135-150 lb-in.

### 3-10. First Stage Cooler

*a. Removal*

(1) Remove second stage cooler (para 3-9).

(2) Remove air inlet fitting (1, fig C-6).

(3) Disconnect cooler (1, fig C-4) from elbows (21) and remove cooler from compressor.

*b. Installation.*

(1) Position cooler (1, fig C-4) on fan guard brackets and loosely connect cooler end nuts to elbows (2).

(2) Install second stage cooler (para 3-9).

(3) Tighten first stage cooler end nuts to 270300 lb-in.

(4) Install air inlet fitting (1, fig C-4).

### 3-11. Aftercooler Tube

*a. Removal.*

(1) Remove first stage cooler (para 3-10).

(2) Disconnect aftercooler tube (10, fig C-4) from union (5, fig C-5) and elbow (11, fig C-6). Remove tube from compressor.

*b. Installation.*

(1) Position aftercooler tube (10, fig C-4) on fan guard brackets and loosely connect tube end nuts to union (5, fig C-5) and elbow (11, fig C-6).

(2) Install first stage cooler (para 3-10).

(3) Tighten aftercooler end nuts to 135-150 lb-in.

### 3-12. Fourth Stage Relief Valve

*a. Removal (fig C-5).*

(1) Remove screw (1), nut (3), and washers (2) securing clamp (11) to bracket (10). Remove clamp (11) from relief valve (7).

(2) Disconnect relief valve tube (8) end nut from relief valve (7) and remove relief valve.

*b. Installation.*

(1) Position relief valve (7) to end of relief valve tube (8). Tighten relief valve tube end nut to 135-150 lb-in.

(2) Position clamp (11) on relief valve (7). Secure clamp (11) and clamp (4) to bracket (10) with screw (1), nut (3), and washers (2).

### 3-13. Fourth Stage Relief Valve Tube

*a. Removal (fig C-5).*

(1) Remove relief valve (para 3-12).

(2) Disconnect relief valve tube (8) from restrictor fitting (9). Remove tube from compressor.

*b. Installation.*

(1) Position relief valve tube (8) to restrictor fitting (9) and loosely connect tube end nut to restrictor fitting.

(2) Install relief valve (para 3-12).

(3) Tighten relief valve tube nut and restrictor fitting to 135-150 lb-in.

### 3-14. Aftercooler

*a. Removal*

(1) Remove first stage air inlet fitting (1, fig C-6).

(2) Remove fan (para 3-6).

(3) Remove four screws (23, fig C-3), lockwashers (24), and flat washers (25) securing fan guard clamps (26) to compressor.

(4) Remove two screws (31), flat washers (30), and nuts (28) securing bracket (36) to clamps (29).

(5) Loosen tube (38) end nut at elbow (39) and move tube away from coolers. Tighten tube end nut if oil sump is not drained.

(6) Remove screw, nut, and washers securing third stage cooler clamp, at relief valve end of cooler, to after cooler clamp.

(7) Remove screw, nut, and washers securing second stage cooler clamp, at relief valve end of cooler, to aftercooler clamp.

(8) Disconnect first stage cooler (1, fig C-4) from elbows. (9).

(9) Disconnect second stage cooler (3) from relief valve (8) and elbow (9).

(10) Disconnect third stage cooler (2, fig C-3) from relief valve (27) and elbow (1).

(11) Disconnect aftercooler tube (10, fig C-4) from union (5, fig C-5) and elbow (11, fig C;6).

(12) Remove coolers, aftercooler tube, and fan guard brackets from compressor.

(13) Remove cylinder head screw (14, fig C8) securing relief valve clamp bracket to head.

(14) Disconnect relief valve tube (8, fig C-5) from restrictor fitting (9). Remove relief valve, relief valve tube, clamp, and clamp bracket from compressor.

(15) Remove screw (1), nut (3), and washers (2) securing aftercooler clamp (4) to bracket (12).

(16) Disconnect aftercooler tube from restrictor fitting (9).

(17) Remove elbow (1, fig C-3) from head.

(18) Turn aftercooler 90° counterclockwise and raise rear of aftercooler to clear relief valve (8, fig C-4) and union (3, fig C-6).

**NOTE**

**Note position of aftercooler to facilitate installation during assembly.**

(19) Remove aftercooler from compressor.

(20) Remove three cushion clamps from after cooler.

*b. Installation.*

(1) Position aftercooler over third stage cylinder.

**NOTE**

**See a (18) above for positioning of aftercooler.**

(2) Install three cushion clamps on aftercooler as shown in figure C-5.

(3) Loosely connect aftercooler end nut to restrictor fitting (9, fig C-5).

(4) Secure clamp (4) to bracket (12) with screw (1), nut (3), and two washers (2).

(5) Tighten aftercooler end nut at restrictor fitting (9, fig C-5) to 135-150 lb-in.

(6) Install elbow (1 fig C-3) and tighten securely.

(7) Position relief valve clamp bracket (10, fig C-3) between cylinder head fins and install head screw (14, fig C-8) and washer (13). Tighten screw to 30-40 lb-in.

(8) Position relief valve tube (8, fig C-5) on restrictor fitting (9) and loosely connect end nut.

(9) Position cushion clamp (11) on relief valve (7). Secure clamp (11) and clamp (4) to bracket (10) with screw (11), nut (3) and two washers (2).

(10) Tighten relief valve tube end nut at restrictor fitting to 135-150 lb-in.

(11) Secure cushion clamp (4) to bracket (12) with screw (1) nut (3) and two washers (2).

(12) Position coolers, aftercooler tube, and fan guard brackets (assembled) on compressor.

**NOTE**

**Do not tighten any nuts or &.screws until all cooler end nuts and fan guard bracket .screws are installed. (13) Connect aftercooler tube (10, fig C-4) to union (5, fig C-5) and elbow (11, fig C-6).**

(14) Connect third stage cooler (2, fig C-3) to relief valve (27) and elbow (1).

(15) Connect second stage cooler (3, fig C-4) to relief valve (8) and elbow (9).

(16) Connect first stage cooler (1) to elbows (2).

(17) Secure second stage cooler clamp (at relief valve end of cooler) to aftercooler clamp with screw (6) nut (7), and two washers (5).

(18) Secure third stage cooler clamp, at relief valve end of cooler, to aftercooler clamp with screw (1, fig C-5) nut (3), and two washers (2).

(19) Loosen tube (38, fig C-3) end nut at elbow (39) (if tightened during disassembly) and position bracket (36) to clamps (29). Secure clamps to bracket with screws (31), washers (30), and nuts (28).

(20) Install four fan guard bracket screws (23, fig C-3), lockwashers (24), and flat washers (25).

(21) Tighten all screws, clamps and tube end nuts installed in steps (13) through (20) above. See paragraph 1-5 for torques.

(22) Install fan (para 3-6).

(23) Install first stage air inlet fitting (1, fig C6).

**3-15. Fan Guard Bracket***a. Removal (fig C-3).*

(1) Remove fan guard (para 3-5).

(2) Remove cooler clamp screws (3), nuts (6), and washers (4) from bracket to be removed.

(3) Remove screw (23), lockwasher (24), and flat washer (25). Remove bracket from compressor.

*b. Installation.*

(1) Position bracket on compressor and install screw (23), lockwasher (24), and flat washer (25). Do not tighten screw (23).

(2) Position fan guard on brackets. Aline bracket screw holes between fan guard parallel traverse bars. Tighten screw (23) installed in step (1) above to 40-45 lb-in.

(3) Position cooler clamp (5) on coolers and secure with two screws (3), nuts (6), and four flat washers (14).

(4) Install fan guard (para 3-5)..

**3-16. Third Stage Relief Valve***a. Removal.*

(1) Disconnect third stage cooler end nut from relief valve (27, fig C-3).

(2) Disconnect aftercooler tube end nut from elbow (11, fig C-6).

(3) Remove screws (10), lockwashers (9), and flat washers (8) securing bracket (7) to fourth stage head. Remove bracket (7) and two spacers (4) from head.

(4) Unscrew relief valve from head.

*b. Installation.***NOTE**

**Apply teflon tape per MIL-I-27730 to relief valve threads prior to installation.**

(1) Install relief valve into fourth stage cylinder inlet port and tighten. Valve must be alined with third stage cooler tube.

(2) Connect third stage cooler tube end nut to relief valve and tighten to 135-150 lb-in.



(3) Position spacers (4, fig C-6) and bracket (7) on fourth stage head and secure with two screws (10), flat washers (8), and lockwashers (9).

(4) Connect aftercooler tube end nut to elbow (11) and tighten to 135-150 lb-in.

### 3-17. Second Stage Relief Valve

#### a. Removal.

(1) Remove third stage cooler (para 3-8).

(2) Disconnect aftercooler tube (10, fig C-4), from union (5, fig C-5).

(3) Disconnect second stage cooler end nut from relief valve (8, fig C-4).

(4) Unscrew relief valve from third stage head.

#### b. Installation.

#### NOTE

**Apply teflon tape per MIL-T-2-7730 to relief valve threads prior to installation.**

(1) Install relief valve into third stage cylinder head inlet port and tighten. Valve must be aligned with second stage cooler tube.

(2) Connect second stage cooler tube end nut to relief valve and tighten to 135-150 lb-in.

(3) Connect aftercooler tube end nut to union (5, fig A-5) and tighten to 135-150 lb-in.

(4) Install third stage cooler (para 3-8).

### 3-18. Fourth Stage Restrictor Fitting

#### a. Removal (fig C-5).

(1) Disconnect fourth stage relief valve tube (18) from restrictor fitting (9).

(2) Disconnect aftercooler (6) from restrictor fitting (9).

(3) Unscrew restrictor fitting (9) from fourth stage cylinder head.

#### b. Installation.

#### NOTE

**Apply teflon tape per MIL-T-27730 to restrictor fitting threads prior to installation**

(1) Install restrictor fitting (9) into fourth stage cylinder head outlet port and tighten. Fitting must be aligned with aftercooler and fourth stage relief valve tube end nuts.

(2) Connect fourth stage relief valve tube (8) to restrictor fitting (9) and tighten to 135-150 lb-in.

(3) Connect aftercooler end nut to restrictor fitting and tighten to 135-130 lb-in.

### 3-19. Discharge Bulkhead Elbow

#### a. Removal (fig C-6).

(1) Disconnect aftercooler tube end nut from elbow (11).

(2) Remove nut (6) and washer (5).

(3) Remove elbow (11) and washer (5) from discharge bracket.

#### b. Installation.

(1) Install elbow (11), with washer (5) through hole in discharge bracket (7). Secure elbow with nut (6) and washer (5).

(2) Connect aftercooler tube to elbow and tighten to 135-150 lb-in.

### 3-20. Discharge Bulkhead Elbow Bracket

#### a. Removal (fig C-6).

(1) Remove elbow from bracket (para 3-19).

(2) Remove two screws (10), lockwasher (9), and flat washers (8) securing bracket to fourth stage head. Remove bracket (7) and two spacers (4) from compressor.

#### b. Installation.

(1) Position two spacers (4) and bracket (7) on fourth stage head.

(2) Secure bracket to head with two flat washers (8), lockwashers (9), and screws (10). Tighten screws to 60.65 lb-in.

(3) Install elbow (11), (para 3-19).

### 3-21. Check Valve

#### a. Removal (fig C-11).

(1) Unscrew check valve (5) from tee (3).

(2) Remove preformed packing (4) from check valve.

#### b. Installation.

(1) Position preformed packing (4) into packing groove of check valve (5).

(2) Install check valve into tee (3) and tighten to 40-6.5 lb-in.

### 3-22. Check Valve Tee

#### a. Removal (fig C-11).

(1) Disconnect tube from tee (3).

(2) Remove check valve (para 3-21).

(3) Loosen nut (39) and unscrew tee (3) from crankcase adapter (1).

#### b. Installation.

(1) With preformed packing (38) back-up ring (4), and nut (39) assembled on tee (3), install tee into crankcase adapter blow-by port.

(2) Connect tube to tee (3).

(3) Tighten nut (39) securely.

### 3-23. Oil Inlet Tube

a. *Removal (fig C-6).* Disconnect tube (13) end nuts from union (3) and elbow (14). Remove tube from compressor.

b. *Installation.* Position tube (13) on union (3) and elbow (14). Tighten tube (13) end nuts to 135-130 lb-in.

### 3-24. Oil Pickup Screen

#### a. Removal (fig C-11).

(1) Remove oil inlet tube (para 3-23).

(2) Unscrew fitting (24) from sump and remove screen (23).

(3) Unscrew pickup screen (23) from fitting (24).

*b. Installation.* (1) Install fitting (24) on pickup screen (23) and tighten securely.

(2) Install preformed packing (22) on fitting (24).

(3) Apply teflon tape per MIL-T-27730 to fitting (24) threads.

(4) Install assembly into sump and tighten fitting (24) securely.

(5) Install oil inlet tube (para 3-23).

### 3-25. Oil Fill and Dipstick Manifold

#### *a. Removal (fig C-10).*

(1) Disconnect oil fill manifold vent tube from check valve tee.

(2) Unscrew and remove dipstick (34) and plug (38) from manifold (39).

(3) Remove screw (1), lockwasher (41), and flat washer (40) securing manifold (39) to head (4).

(4) Disconnect first stage cooler tube end nut from elbow at head (4).

(5) Remove six screws (2) and lockwashers (3) securing head (4) to cylinder.

(6) Remove head (4) and preformed packing (5) from cylinder.

(7) Remove manifold (39) and preformed packing (37) from compressor.

#### *b. Installation.*

(1) Install preformed packing (37) in fitting (36).

(2) Install manifold dipstick tube into fitting 1361 and preformed packing (37).

(3) Position preformed packing (5) and first stage head (4) on cylinder. Secure head with six screws (2) and lockwashers (3). Tighten evenly to 30-335 lb-in.

(4) Secure manifold (39) to head (4) with screw (1), lockwasher (41), and flat washer (40). Tighten securely.

(5) Connect first stage cooler tube end nut to elbow in head (4). Tighten to 270-300 lb-in.

### 3-26. Rear Oil Seal

#### *a. Removal (fig C-11).*

(1) Remove oil fill and dipstick manifold (para 3-25).

(2) Remove four screws (41) and lockwashers (40) securing adapter (1) to crankcase. Remove adapter from crankshaft.

(3) Remove wavewasher (31) and preformed packing (2) from adapter.

(4) Using a suitable driver, remove seal (32) from adapter (1).

#### *b. Installation.*

(1) Using oil seal insertion tools (3, fig C-12) install seal (32) into adapter (1).

(2) Position preformed packing (2) into groove on adapter (1).

### CAUTION

**Do not damage preformed packing (2), wavewasher (31), or lip of seal (32) during installation of adapter (1) on crankshaft and crankcase.**

(3) Position wavewasher (31) into adapter (1). Position adapter on crankshaft with blow-by port facing down. Secure adapter with four lockwashers (40) and screws (41). Tighten screws to 40-65 lb-in.

### 3-27. Front Oil Seal

#### *a. Removal (fig C-11).*

(1) Remove four fan guard brackets (para 315).

(2) Remove three screws (21), lockwashers (20), and flat washers (19) securing oil pump housing (17) to oil pump plate and remove housing. Remove and discard gasket (16).

(3) Using a suitable driver, remove seal (18) from housing (17).

#### *b. Installation.*

(1) Using a suitable driver, install seal (18) into housing (17).

(2) Position housing (17) with new gasket (16) on crankshaft with relief valve facing up. Install three screws (21), lockwashers (20) and flat washers (19).

(3) Install four fan guard brackets (para 315). 3-28. Air and Hydraulic Fittings

#### *a. Removal.*

(1) Refer to applicable removal procedures and remove compressor components, as required, to gain access to fitting to be removed.

(2) Disconnect tube (s) from fitting to be removed and unscrew fitting from compressor.

#### *b. Installation.*

### NOTE

**During installation of pipe threaded fittings use teflon tape per MIL-T-27730 at threads.**

(1) Install fitting and tighten securely with elbow fittings aligned with connecting tube.

(2) Connect tube (s) to fitting and tighten in accordance with paragraph 1-5.

(3) Install components removed in a.(1) above.

## APPENDIX A

## REFERENCES

- 
- |  |  |
|--|--|
| <b>A-1. Fire Protection</b><br>TB 5-4200-200-10  | <b>Hand Portable Fire Extinguishers Approved For Army Users</b>  |
| <b>A-2. Lubrication</b><br>C9100-IL<br>LO 9-2350-232-12                                  | <b>Identification List for Fuels, Lubricants, Oils, and Waxes<br/>Lubrication Order</b>  |
| <b>A-3. Painting</b><br>TM 9-213   | <b>Painting Instructions for Field Use</b>   |
| <b>A-4. Maintenance</b><br>TM 38-750<br>TM 9-2350-232-10<br>TM 9-2350-232-20-1<br>and -2 | <b>The Army Maintenance Management Systems<br/>Operator Manual for Tank, Combat, M60A2<br/>Organizational Maintenance Manual for Tank, Combat, M60A2</b> |
| <b>A-5. Shipment and Storage</b><br>TB 740-97-2<br>TM 740-93-1                           | <b>Preservation of USAMEC Mechanical Equipment for Shipment and Storage<br/>Administrative Storage of Equipment</b>                                      |
| <b>A-6. Destruction to Prevent<br/>Enemy Use</b><br>TM 750-244-3                         | <b>Procedures for Destruction of Equipment to Prevent Enemy Use.</b>   |

## APPENDIX B

## MAINTENANCE ALLOCATION CHART

## Section I. INTRODUCTION

**B-1. General**

a. This section provides a general explanation of all maintenance and repair functions authorized at various maintenance levels.

b. Section II designates overall responsibility for the performance of maintenance functions on the identified end item or component and the work measurement time required to perform the functions by the designated maintenance level. The implementation of the maintenance functions upon the end item or component will be consistent with the assigned maintenance functions.

c. Section III lists the special tools and test equipment required for each maintenance function as referenced from Section II.

d. Section IV contains supplemental instructions or explanatory notes for a particular maintenance function. (Not Applicable).

**B-2. Explanation of Columns in Section II.**

a. *Column (1). Group Number.* A number is assigned to each group in a top down breakdown sequence. The applicable groups are listed on the MAC in disassembly sequence beginning with the first group removed.

b. *Column (2). Functional Group.* This column contains a brief description of the components of each numerical group.

c. *Column (3). Maintenance Functions.* This column lists the various maintenance functions (IA through K). The lowest maintenance level authorized to perform these functions is indicated by a symbol in the appropriate column. The symbol designations for the various maintenance levels are as follows:

C-Operator or crew  
O-Organization maintenance.  
F-Direct support maintenance.  
H-General support maintenance.  
D-Depot maintenance.

The maintenance functions are defined as follows:

A-Inspect. To determine serviceability of an item by comparing its physical, mechanical, and electrical characteristics with established standards through examination.

B-Test. To verify serviceability and detect incipient failure by measuring the mechanical or electrical characteristics of an item and comparing those characteristics with prescribed standards.

C-Service. Operations required periodically to keep an item in proper operating condition, i.e., to clean, to preserve, to drain, to paint, or to replenish fuel, lubricants, hydraulic fluids, or compressed air supplies.

D-Adjust. To maintain within prescribed limits, by bringing into proper or exact position, or by setting the operating characteristics to specified parameters.

E-Align. To adjust specified variable elements of an item to bring about optimum or desired performance.

F-Calibrate. To determine and cause corrections to be made or to be adjusted on instruments to test measuring and diagnostic equipments used in precision measurement. Consists of comparisons of two instruments, one of which is a certified standard of known accuracy, to detect and adjust any discrepancy in the accuracy of the instrument being compared.

G-Install. The act of emplacing, seating, or fixing into position an item, part, or module (component or assembly) in a manner to allow the proper functioning of an equipment or system.

H-Replace. The act of substituting a serviceable like type part, subassembly, or module (component or assembly) for an unserviceable counterpart.

I-Repair. The application of maintenance services (inspect, test, service, adjust, align, calibrate, or replace) or other maintenance actions (welding, grinding, riveting, straightening, facing, remachining or resurfacing) to restore serviceability to an item by correcting specific damage, fault, malfunction, or failure in a part, subassembly, module (component or assembly), end item, or system.

J-Overhaul. That maintenance effort (service / action ) necessary to restore an item to a completely serviceable/ operational condition as prescribed by maintenance standards (i.e., DMWR) in appropriate technical publication. Overhaul is normally the highest degree of maintenance performed by the Army. Overhaul does not normally return an item to like new condition.

K-Rebuild. Consists of those services / actions necessary for the restoration of unserviceable equipment to a like new condition in accordance with original manufacturing standards. Rebuild is the highest degree of materiel maintenance applied to Army equipment. The rebuild operation includes the act of returning to zero those age measurement (hours / miles, etc.) considered in classifying Army equipment / components.

*d. Column (4), Tools and Equipment.* This column is provided for referencing by code the special tools and test equipment, (sec. III) required to perform the maintenance functions (sec. II).

*e. Column (5), Remarks.* This column is provided for referencing by code the remarks (sec. IV) pertinent to the maintenance functions.

**B-3. Explanation of Columns in Section III.**

*a. Reference Code.* This column consists of a number and a letter separated by a dash entered from column 4 on the MAC. The number references the special tools and test equipment requirements and the letter represents the specific maintenance function the item is to be used with. The letter is representative of columns A through K on the MAC.

*b. Maintenance Category.* This column shows the lowest level of Maintenance authorized to use the special tools or test equipment.

*c. Nomenclature.* This column lists the name or identification of the tools or test equipment.

*d. Tool Number.* This column lists the manufacturer's code and part number, or Federal Stock Number of tools and test equipment.

**B-4. Explanation of Columns in Section IV. (NOT APPLICABLE).**

Section II. MAINTENANCE ALLOCATION CHART

(1) Group No.	(2) Functional group	(3) Maintenance functions											(4) Tools and equipment	(5) Remarks			
		A	B	C	D	E	F	G	H	I	J	K					
		Inspect	Test	Service	Adjust	Align	Calibrate	Install	Replace	Repair	Overhaul	Rebuild					
5000	<b>GROUP 50 PNEUMATIC EQUIPMENT</b>																
	Compressor assembly, air	O	D	O						F		D					I-J
	Compressor, basic	F	D		D					F		D					
	Valve, relief, second stage	F	D		D					F							
	Valve, relief, third stage	F	D		D					F							
	Valve, relief, fourth stage	F	D		D					F							
Valve, relief, oil pump	D	D		D					D								

**Section III. SPECIAL TOOL AND SPECIAL TEST EQUIPMENT REQUIREMENTS**

Reference code	Maintenance Category	Nomenclature	Tool number
1-J	D Refer to Table 3-1		

APPENDIX C

ORGANIZATIONAL, DIRECT SUPPORT, AND GENERAL  
SUPPORT MAINTENANCE REPAIR PARTS  
AND SPECIAL TOOLS LIST  
(INCLUDING DEPOT MAINTENANCE  
REPAIR PARTS AND SPECIAL TOOLS)

Section I. INTRODUCTION

**C-1. Scope**

This Appendix lists repair parts and special tools required for the performance of organizational, direct support, general support, and depot maintenance of the air compressor.

**C-2. General**

This Repair Parts and Special Tools list is divided into the following sections:

*a. Repair Parts List-Section II.* A list of repair parts authorized at the organizational level for the performance of maintenance.

*b. Repair Parts List-Section III.* A list of repair parts authorized at the direct support, general support, and depot level for the performance of maintenance.

*c. Special Tools List-Section IV.* A list of special tools, test and support equipment authorized for the performance of maintenance at the direct support, general support, and depot level.

*d. Federal Stock Numbers and Reference Number Index-Section V.* A list, in ascending numerical sequence, of all Federal stock numbers appearing in the listings, followed by a list, in alphameric sequence, of all reference numbers appearing in the listings. Federal stock number and reference numbers are cross-referenced to each illustration figure and item number appearance.

**C 3. Explanation of Columns**

The following provides an explanation of columns found in the tabular listings.

*a. Source, Maintenance, and Recoverability Codes (SMR).* The SMR code is composed of three parts consisting of a two position source code, a two position maintenance code, and a one position recoverability code as follows:

(1) Source codes (2 positions). Codes entered in the first and second position indicate the source for acquiring the item for replacement purposes. Source codes are:

Code	Explanation
PA	Item procured and stocked for anticipated or known usage.
PB	Item procured and stocked for insurance purposes because essentiality dictates that a minimum quantity be available in the supply system.
PC	Item procured and stocked and which otherwise would be coded PA except that it is deteriorative in nature.
PD	Support item, excluding support equipment, procured for initial issue or outfitting and stocked only for subsequent or additional initial issue or outfittings. Not subject to automatic replacement.
PE	Support equipment procured and stocked for initial issue or outfitting to specified maintenance repair activities.
PF	Support equipment which will not be stocked but a which will be centrally procured on demand.
PG	Item procured and stocked to provide for sustained support for the life of the equipment. It is applied to an item peculiar to the equipment which because of probable discontinuance or shut-down of production facilities would prove uneconomical to reproduce at a later time.
KD	An item of depot overhaul repair kit and not purchased separately. Depot kit defined as a kit that provides item required at the time of overhaul of repair.
KF	An item of a maintenance kit and not purchased separately. Maintenance kit defined as a kit that provides an item that can be replaced at organizational or intermediate levels of maintenance.
KB	An item included in both a depot overhaul repair kit and a maintenance kit.
MO	Item to be manufactured or fabricated at organizational level.
MF	Item to be manufactured or fabricated at (direct support maintenance level.
MH	Item to be manufactured or fabricated at general support maintenance level.
MD	Item to be manufactured or fabricated at depot maintenance level.
AO	Item to be assembled at organizational level.
AF	Item to be assembled at direct support maintenance level.



All	Item to be assembled at general support maintenance level.
AD	Item to be assembled at depot maintenance level.
XA	Item that is not procured or stocked because the requirements for the item will result in the replacement of the next higher assembly.
XB	Item is not procured or stocked. If not available through salvage, requisition.
XC	Installation drawing, diagram, instruction sheet, field service drawing, that is identified by manufacturer's part number.

(2) *Maintenance codes (2 position).* Codes - entered in the third and fourth position are as follows:

(a) *Third position.* The maintenance code entered in the third position indicates the lowest maintenance level authorized to remove/ replace, and use the item. When a maintenance code is not used a (-) will be entered. Maintenance codes are:

Code	Explanation
O	Support item is removed. replaced. used at organizational level.
F	Support item is removed. replaced. used at direct support level.
H	Support item is removed. replaced. used at general support level.
D	Support item is removed. replaced. used at depot level only.

(b) *Fourth position.* The maintenance code entered in the fourth position indicates whether the item is to be repaired and identifies the lowest maintenance level capable or performing complete repair. When a maintenance code is not used a dash (-) will be entered. Maintenance codes are:

Code	Explanation
O	The lowest maintenance level capable of complete repair is organizational.
F	The lowest maintenance level capable of complete repair is direct support.
H	The lowest maintenance level capable of complete repair is general support.
D	The lowest maintenance level capable of complete repair is depot.
L	Repair restricted to designated specialized repair activity.
Z	Nonrepairable. No repair authorized.
B	No repair authorized. The item may be reconditioned by adjusting, lubricating, etc., at the user level. No parts or special tools are procured for maintenance of this time.

(3) *Recoverability codes (1 position).* The recoverability codes entered in the fifth position are assigned to support items to indicate the disposition action on unserviceable items. When recoverability code is not used a dash (-) will be entered. Recoverability codes are:

Code	Explanation
Z	Nonrepairable. When unserviceable, condemn and dispose of at the level indicated in position 3.
O	Repairable. When uneconomically repairable, condemn and dispose of at organizational level.
F	Repairable. When uneconomically repairable, condemn and dispose of at direct support level.
H	Repairable. When uneconomically repairable, condemn and dispose of at general support level.
D	Repairable. When beyond lower level repair capability, return to depot. Condemnation and disposal not authorized below depot level.
L	Repairable. Repair, condemnation and disposal not authorized below depot / Specialized Repair Activity level.
A	Item requires special handling or condemnation procedures because of specific reasons (i.e., precious metal content, high dollar value, critical material or hazardous material).

b. *Federal Stock Number.* Indicates the Federal stock number assigned to the item and will be used for requisitioning purposes.

c. *Description.* Indicates the Federal item name and a minimum description required to identify the item. The last line indicates the reference number followed by the applicable Federal Supply Code for Manufacturer (FSCM) in parentheses. The FSCM is used as, an element in item identification to designate manufacturer or distributor or Government agency, etc., and is identified in SB 708-42. Items that are included in kits or sets are listed below the item of the kit or set with quantity of each of the kit or set indicated in front of the item name.

d. *Unit of Measure (U/M).* Indicates the standard or basic quantity by which the listed item is used in performing the actual maintenance function. This measure is expressed by a two character alphabetical abbreviation. e.g., ea. in. pr. etc., and is the basis used to indicate quantities and allowances in subsequent columns. When the units of measure differs from the unit of issue the lowest unit of issue that will be requisitioned.

e. *Quantity Incorporated in Unit.* Indicates the quantity of the item used in the breakout shown on the illustration figure, which is prepared for a functional group, subfunctional group, or an assembly. A "V" appearing in this column in lieu of a quantity indicates that no specific quantity is applicable. e.g., shims, spacers, etc.

f. *15-Day Organizational Maintenance Allowances.*

(1) The repair parts reflected represent those authorized for use at the organizational category and will be requisitioned on an "as required" basis until stockage is based on demand in accordance with AR 735-35 or AR 710-2. Those items containing a quantity in the maintenance allowance column are essential repair parts which must be stocked in the minimum quantities indicated (AR700-18).

(2) Major Army commanders are authorized to approved reductions in the range of support items authorized for use in units within their commands. Recommendations for increases in range of items authorized for use will be forwarded to the national level maintenance management agency responsible for the preparation of the repair parts and special tools list. This agency will take action on such recommendations. Any changes approved will be reflected in a revision to the repair parts and special tools list.

*g. 30-Day DS/ GS Maintenance Allowances.*

(1) The repair parts list will include asterisk entries in separate columns-one for direct support (DS) and one for general support (GS) as appropriate, to indicate the total range of repair parts authorized for use at that category. They will be requisitioned initially on an "as required" basis. The repair part authorized at DS / GS levels will be those authorized for the maintenance mission at these levels. Requirements for repair parts stockage and for distribution to supported units will be based on demand and determined in accordance with AR 711-16 and AR 710-2. Those items containing a quantity in the maintenance allowance column are essential repair parts which must be stocked in the minimum quantities indicated (AR 700-18).

(2) Special Tools or Test, Measurement, and Diagnostic Equipment (TMDE) and other support equipment peculiar to an item are listed with quantities in the appropriate density spread / allowance columns.

*h. 1-Year Allowances Per 100 Equipment / Contingency Planning Purposes.* The repair parts list will include asterisk entries in this column for each item required for distribution and contingency planning purposes. Requirements for repair part stockage and for distribution to supported limits will be based on demand and determined in accordance with AR 711-16 and AR 710.9.

*i. Depot Maintenance Allowance Per 100 Equipments.* The repair parts list will include asterisk entries in this column for each item required for depot maintenance of 100 equipments.

*j. Illustrations.* This column is divided as follows: TM 5-4310-340-24

(1) *Figure number.* Indicates the figure number of the illustration on which the item is shown.

(2) *Item number.* Indicates the callout number used to reference the item on the illustration.

(2) *Item number.* Indicates the callout number used to reference the item on the illustration.

#### **C-4. Special Information**

a. The basis of issue for authorized special tools test and support equipment is the number of end items of equipment and the number of maintenance personnel allocated to perform the required maintenance operation.

b. Repair parts kits and gasket sets appear as the last entries in the repair parts listing for the group or assembly to which they apply.

#### **C-5. How to Locate Repair Parts**

a. When Federal stock number or reference number is unknown.

(1) *First.* Using the table of contents, determine the functional sub-group within which the repair part belongs, i.e., engine assembly, transmission assembly. This is necessary since illustrations are prepared for functional sub-groups and listings are divided into the same groups.

(2) *Second.* Find the illustrations covering the functional sub-group to which the repair part belongs.

(3) *Third.* Identify the repair part on the illustration and note the illustration figure and item number of the repair part.

(4) *Fourth.* Using the Repair Parts Listing, find the functional sub-group to which the repair part belongs and locate the illustration figure and item number noted on the illustration.

b. *When Federal stock number or reference number is known:*

(1) *First.* Using the Index of Federal stock numbers and reference numbers, find the pertinent Federal stock number or reference number. This index is in ascending FSN sequence followed by a list of reference numbers in ascending alphameric sequence, cross-referenced to illustration figure number and item number.

(2) *Second.* Using the repair parts listing, find the functional sub-group of the repair parts and the illustration figure number and item number referenced in the Index of Federal stock numbers and reference numbers.

SECTION II.

TM 5-4310-340-24

REPAIR PARTS FOR ORGANIZATIONAL MAINTENANCE											
(1) SMR CODE	(2) FEDERAL STOCK NUMBER	(3) DESCRIPTION Reference Number & Mfr. Code Usable on Code		(4) UNIT OF MEAS	(5) QTY INC IN UNIT	(6) 15 DAY ORG MAINT ALLOWANCE				(7) ILLUSTRATION	
						(a) 1-5	(b) 6-20	(c) 21-50	(d) 51-100	(a) FIGURE NO.	(b) ITEM NO.
		<b>GROUP 50 - PNEUMATIC EQUIPMENT 5000 - AIR COMPRESSOR ASSEMBLY</b>									
PAODD	4310-228-0766	COMPRESSOR ASSEMBLY: closed breech scavenge system 894780 (33525)		EA	1	*	*	*	1	C-1	1
PAOZZ		CAP: oil drain tube 216221 (33525)		EA	1	*	*	*	*	C-3	34
PAOZZ.		CHAIN: oil drain tube cap 258500 (33525)		EA	V	*	*	*	*	C-3	35
PAOZZ	4730-008-7247	FITTING: air inlet 255207 (33525)		EA	1	*	*	*	*	C-6	1
PAOZZ	6680-009-3569	DIPSTICK: oil. level indicating 292932 (33525)		EA	1	*	*	*	1	C-10	34
PCOZZ	5330-009-0553	PACKING, PREFORMED: oil level dipstick (1), oil fill plug (1) 5729-0906 (33525)		EA	2	*	*	*	1	C-10	35
PAOZZ		PLUG: oil fill 258502 (33525)		EA	1	*	*	*	*	C-10	38

REPAIR PARTS FOR DIRECT SUPPORT, GENERAL SUPPORT, AND DEPOT MAINTENANCE																
(1) SMR CODE	(2) FEDERAL STOCK NUMBER	(3) DESCRIPTION Reference Number & Mfr. Code Usable on Code		(4) UNIT OF MEAS	(5) QTY INC IN UNIT	(6) 30 DAY DS MAINTENANCE ALLOWANCE			(7) 30 DAY GS MAINTENANCE ALLOWANCE			(8) 1 YR ALW PER 100 EQUIP CNTGCT	(9) DEPOT MAINT ALW PER 100 EQUIP	(10) ILLUSTRATION		
						(a) 1-20	(b) 21-50	(c) 51-100	(a) 1-20	(b) 21-50	(c) 51-100			(a) FIGURE NO.	(b) ITEM NO.	
		<b>GROUP 50 - PNEUMATIC EQUIPMENT 5000 - AIR COMPRESSOR ASSEMBLY</b>														
PAODD	4310-228-0766	COMPRESSOR ASSEMBLY: closed breech scavenge system 894780 (33525)		EA	1	*	*	1	*	*	1	*	*	C-1	1	
XBDDL		COMPRESSOR: basic 894791 (33525)		EA	1									C-2	1	
PAFZZ	4730-331-4950	ELBOW: 90°, third stage cooler to compressor AN 8224C (88044)		EA	1	*	*	*	*	*	*	*	*	C-3	1	
PAFZZ	4310-008-9888	COOLER: third stage 894810 (33525)		EA	1	*	*	*	*	*	*	*	*	C-3	2	
PAFZZ		SCREW: cooler clamp 5292-0622 (33525)		EA	8	*	*	*	*	*	*	*	*	C-3	3	
PAFZZ	5310-531-9514	WASHER, FLAT: cooler clamp screw AN960C6 (88044)		EA	14	*	*	*	*	*	*	*	*	C-3	4	
PAFZZ	5340-097-7150	CLAMP: cooler 254854 (33525)		EA	4	*	*	1	*	*	1	*	*	C-3	5	
PAFZZ		NUT: cooler clamp 1979-0600 (33525)		EA	8	*	*	*	*	*	*	*	*	C-3	6	
PAFFF	1040-970-8426	GUARD: fan 290641 (33525)		EA	1	*	*	1	*	*	1	*	*	C-3	7	
PAFZZ	5310-053-3551	WASHER: fan guard screw 213516 (33525)		EA	4	*	*	*	*	*	*	*	*	C-3	8	
PAFZZ		WASHER, LOCK: fan guard screw MS122055 (96906)		EA	4	*	*	*	*	*	*	*	*	C-3	9	
PAFZZ		SCREW: fan guard 5292-1108 (33525)		EA	4	*	*	*	*	*	*	*	*	C-3	10	
XBFZZ		SCREW: fan hub cover 1563-1414 (33525)		EA	5									C-3	11	
XBFZZ		WASHER, FLAT: fan hub cover screw 5337-0400 (33525)		EA	5									C-3	12	
XBFZZ		COVER: fan hub 280462 (33525)		EA	1									C-3	13	
PCFZZ		SEAL: fan hub cover 258439 (33525)		EA	1	*	*	*	*	*	*	*	*	C-3	14	
PAFZZ	5305-150-1511	SCREW: fan 254804 (33525)		EA	1	*	*	1	*	*	1	*	*	C-3	15	
PAFZZ	5310-009-9244	WASHER, FLAT: fan 254695 (33525)		EA	1	*	*	1	*	*	1	*	*	C-3	16	
PAFZZ	1650-605-0252	COVER: fan spring 204388 (33525)		EA	1	*	*	1	*	*	1	*	*	C-3	17	
PAFZZ	5360-328-3690	SPRING: fan 204387 (33525)		EA	1	*	*	1	*	*	1	*	*	C-3	18	

SECTION III

TM 5-4310-340-24

REPAIR PARTS FOR DIRECT SUPPORT, GENERAL SUPPORT, AND DEPOT MAINTENANCE															
(1) SMR CODE	(2) FEDERAL STOCK NUMBER	(3) DESCRIPTION Reference Number & Mfr. Code Usable on Code		(4) UNIT OF MEAS	(5) QTY INC IN UNIT	(6) 30 DAY DS MAINTENANCE ALLOWANCE			(7) 30 DAY GS MAINTENANCE ALLOWANCE			(8) 1 YR ALW PER 100 EQUIP CNTGCY	(9) DEPOT MAINT ALW PER 100 EQUIP	(10) ILLUSTRATION	
						(a) 1-20	(b) 21-50	(c) 51-100	(a) 1-20	(b) 21-50	(c) 51-100			(a) FIGURE NO.	(b) ITEM NO.
PAFZZ	5340-531-6992	SPRING: fan spring lock 205039 (33525)		EA	1	*	*	1	*	*	1	*	*	C-3	19
PAFZZ	3120-009-0551	BUSHING: fan 254693 (33525)		EA	1	*	*	1	*	*	1	*	*	C-3	20
PAFZZ	4310-008-9891	FAN: compressor cooling 876005 (33525)		EA	1	*	*	1	*	*	1	*	*	C-3	21
PAFZZ	5310-091-1231	WASHER, THRUST: fan 254694 (33525)		EA	1	*	*	1	*	*	1	*	*	C-3	22
PAFZZ		SCREW: fan guard bracket 1563-1614 (33525)		EA	4	*	*	*	*	*	*	*	*	C-3	23
PAFZZ	5310-812-3373	WASHER, LOCK: fan guard bracket screw MS122057 (96906)		EA	4	*	*	*	*	*	*	*	*	C-3	24
PAFZZ	5310-515-7449	WASHER, FLAT: fan guard bracket screw AN960C416 (88044)		EA	4	*	*	*	*	*	*	*	*	C-3	25
PAFZZ	5340-150-1191	BRACKET: fan guard 277869 (33525)		EA	4	*	*	*	*	*	*	*	*	C-3	26
PAFZZ	4820-008-7246	VALVE: third stage relief 876034 (33525)		EA	1	*	*	1	*	*	1	*	*	C-3	27
XBFZZ		NUT: oil drain tube bracket screw 27FK-832 (56878)		EA	2									C-3	28
XBFZZ		CLAMP: cushioned, oil drain tube support 754-10-2-6-HT (83930)		EA	2									C-3	29
XBFZZ		WASHER, FLAT: oil drain tube bracket screw 5110-0800 (33525)		EA	2									C-3	30
XBFZZ		SCREW: oil drain tube bracket 1563-0809 (33525)		EA	2									C-3	31
PAFZZ		LOCKWIRE: fan hub cap screw		FT	V	*	*	*	*	*	*	*	*	C-3	32
XBFZZ		NUT: oil drain tube union 5811-0402 (33525)		EA	1									C-3	33
PAOZZ		CAP: oil drain tube 216221 (33525)		EA	1	*	*	*	*	*	*	*	*	C-3	34
PAOZZ		CHAIN: oil drain tube cap 258500 (33525)		FT	V	*	*	*	*	*	*	*	*	C-3	35
XBFZZ		BRACKET: oil drain union 258499 (33.525)		EA	I									C-3	36
XBFZZ		UNION: bulkhead, oil drain tube 5862-0402 (33525)		EA	1									C-3	37
XBFZZ		TUBE ASSEMBLY: oil drain 844192 (33525)		EA	1									C-3	38
PAFZZ		ELBOW: 90°, oil drain 243616 (33525)		EA	1	*	*	*	*	*	*	*	*	C-3	39

SECTION III

TM 5-4310-340-24

REPAIR PARTS FOR DIRECT SUPPORT, GENERAL SUPPORT, AND DEPOT MAINTENANCE															
(1) SMR CODE	(2) FEDERAL STOCK NUMBER	(3) DESCRIPTION Reference Number & Mfr. Code Usable on Code		(4) UNIT OF MEAS	(5) QTY INC IN UNIT	(6) 30 DAY DS MAINTENANCE ALLOWANCE			(7) 30 DAY GS MAINTENANCE ALLOWANCE			(8) 1 YR ALW PER 100 EQUIP CNTGCT	(9) DEPOT MAINT ALW PER 100 EQUIP	(10) ILLUSTRATION	
						(a) 1-20	(b) 21-50	(c) 51-100	(a) 1-20	(b) 21-50	(c) 51-100			(a) FIGURE NO.	(b) ITEM NO.
PAFZZ	4310-008-9887	COOLER: first stage 894805 (33525)		EA	1	*	*	1	*	*	1	*	*	C-4	1
PAFZZ	4730-855-0698	ELBOW: 90°, first stage cooler MS20822-6D (96906)		EA	2	*	*	1	*	*	1	*	*	C-4	2
PAFZZ	4310-008-9886	COOLER: second stage 894804 (33525)		EA	1	*	*	1	*	*	1	*	*	C-4	3
XBFZZ		CLAMP: cushioned, first and second stage cooler support 754-10-2-6-HT (83930)		EA	2									C-4	4
PAFZZ	5310-531-9514	WASHER, FLAT: cooler clamp screw AN960C6 (88044)		EA	2	*	*	*	*	*	*	*	*	C-4	5
PAFZZ		SCREW: cooler clamp SrCP-0810 (11828)		EA	1	*	*	*	*	*	*	*	*	C-4	6
PAFZZ		NUT: cooler clamp screw 27FK-832 (56878)		EA	1	*	*	*	*	*	*	*	*	C-4	7
PAFZZ	4310-008-9892	VALVE: second stage relief 875551 (33525)		EA	1	*	*	1	*	*	1	*	*	C-4	8
PAFZZ	4730-186-9961	ELBOW: 90°, second stage cooler MS20822-4D (96906)		EA	1	*	*	*	*	*	*	*	*	C-4	9
PAFZZ	4710-009-2170	TUBE: aftercooler 894821 (33525)		EA	1	*	*	1	*	*	1	*	*	C-4	10
PAFZZ		SCREW: cooler clamp STCP-0810 (11828)		EA	4	*	*	*	*	*	*	*	*	C-5	1
PAFZZ	5315-515-8058	WASHER, FLAT: cooler clamp screw AN960-08 (88044)		EA	8	*	*	*	*	*	*	*	*	C-5	2
PAFZZ		NUT: cooler clamp screw 27FK-832 (56878)		EA	4	*	*	*	*	*	*	*	*	C-5	3
XBFZZ		CLAMP: cushioned, cooler support 754-10-2-6-HT (83930)		EA	6									C-5	4
XBFZZ		UNION: aftercooler AN815-4C (88044)		EA	1									C-5	5
PAFZZ	4310-008-9889	AFTERCOOLER: compressor air system 894819 (33525)		EA	1	*	*	1	*	*	1	*	*	C-5	6
PAFZZ	4820-008-9890	VALVE: fourth stage relief 876029-4500 (33525)		EA	1	*	*	1	*	*	1	*	*	C-5	7
PAFZZ	4710-009-2172	TUBE: fourth stage relief valve 876031 (33525)		EA	1	*	*	1	*	*	1	*	*	C-5	8
PAFZZ	4730-008-7245	FITTING: restrictor 843740 (33525)		EA	1	*	*	1	*	*	1	*	*	C-5	9
XBFZZ		BRACKET: cooler support (33525)		EA	1									C-5	10
PAFZZ	5340-598-0523	CLAMP: cushioned, relief valve 754-14-2-8 (83903)		EA	1	*	*	*	*	*	*	*	*	C-5	11

SECTION III

TM 5-4310-340-24

REPAIR PARTS FOR DIRECT SUPPORT, GENERAL SUPPORT, AND DEPOT MAINTENANCE															
(1) SMR CODE	(2) FEDERAL STOCK NUMBER	(3) DESCRIPTION Reference Number & Mfr. Code Usable on Code		(4) UNIT OF MEAS	(5) QTY INC IN UNIT	(6) 30 DAY DS MAINTENANCE ALLOWANCE			(7) 30 DAY GS MAINTENANCE ALLOWANCE			(8) 1 YR ALW PER 100 EQUIP CNTGCY	(9) DEPOT MAINT ALW PER 100 EQUIP	(10) ILLUSTRATION	
						(a) 1-20	(b) 21-50	(c) 51-100	(a) 1-20	(b) 21-50	(c) 51-100			(a) FIGURE NO.	(b) ITEM NO.
XBFZZ		BRACKET: cooler support (33525)		EA	1									C-5	12
PAOZZ	4730-008-7247	FITTING: air inlet 255207 (33525)		EA	1	*	*	1	*	*	1	*	*	C-6	1
XBFZZ		CAP: oil pressure check port union AN929-4 (88044)		EA	1									C-6	2
PAFZZ	4730-240-5905	UNION: oil pressure check port (1), oil inlet port (1) AN816-4D (88044)		EA	2	*	*	*	*	*	*	*	*	C-6	3
PAFZZ	5365-009-3943	SPACER: discharge bracket mounting 254845 (33525)		EA	2	*	*	1	*	*	1	*	*	C-6	4
PAFZZ	5310-167-0822	WASHER, FLAT: bulkhead elbow AN960-716 (88044)		EA	2	*	*	*	*	*	*	*	*	C-6	5
PAFZZ	5310-079-1967	NUT: bulkhead elbow AN924-4J (88044)		EA	1	*	*	*	*	*	*	*	*	C-6	6
XBFZZ		BRACKET: discharge 277849 (33525)		EA	1									C-6	7
PAFZZ	5310-141-1795	WASHER, FLAT: discharge bracket screw AN960416 (88044)		EA	2	*	*	*	*	*	*	*	*	C-6	8
PAFZZ	5310-812-3373	WASHER, LOCK: discharge bracket screw MS122057 (96906)		EA	2	*	*	*	*	*	*	*	*	C-6	9
PAFZZ		SCREW: discharge bracket 5833-1656 (33525)		EA	2	*	*	*	*	*	*	*	*	C-6	10
PAFZZ	4730-807-2274	ELBOW: 90°, bulkhead MS21908-4C (96906)		EA	1	*	*	*	*	*	*	*	*	C-6	11
XBFZZ		PLATE: identification 254799 (33525)		EA	1									C-6	12
PAFZZ	4710-009-2171	TUBE: oil inlet 894808 (33525)		EA	1	*	*	1	*	*	1	*	*	C-6	13
PAFZZ		ELBOW: 45°, oil inlet tube MS20823-4C (96906)		EA	1	*	*	*	*	*	*	*	*	C-6	14
KDDZZ		PACKING, PREFORMED: fourth stage cylinder 5729-0912 (33525)		EA	1								See Kit 5365-255-5605	C-7	1
KDDZZ		SEAL: ring, fourth stage cylinder 255580 (33525)		EA	2								See Kit 5365-255-5605	C-7	2
KDDZZ		VALVE: outlet, fourth stage cylinder 213182 (33525)		EA	1								See Kit 5365-255-5605	C-7	3
KDDZZ		SPRING: outlet valve, fourth stage cylinder 245532 (33525)		EA	1								See Kit 5365-255-5605	C-7	4
KDDZZ		PIN: fourth stage support plate 213176 (33525)		EA	1								See Kit 5365-255-5605	C-7	5
XBDZZ		PLATE: support, fourth stage cylinder 245519 (33525)		EA	1								See Kit 5365-255-5605	C-7	6

SECTION III

TM 5-4310-340-24

REPAIR PARTS FOR DIRECT SUPPORT, GENERAL SUPPORT, AND DEPOT MAINTENANCE															
(1) SMR CODE	(2) FEDERAL STOCK NUMBER	(3) DESCRIPTION Reference Number & Mfr. Code Usable on Code		(4) UNIT OF MEAS	(5) QTY INC IN UNIT	(6) 30 DAY DS MAINTENANCE ALLOWANCE			(7) 30 DAY GS MAINTENANCE ALLOWANCE			(8) 1 YR ALW PER 100 EQUIP CNTGCT	(9) DEPOT MAINT ALW PER 100 EQUIP	(10) ILLUSTRATION	
						(a) 1-20	(b) 21-50	(c) 51-100	(a) 1-20	(b) 21-50	(c) 51-100			(a) FIGURE NO.	(b) ITEM NO.
KDDZZ		RING: back-up, fourth stage cylinder 215831 (33525)		EA	1				See Kit 5365-255-5605					C-7	7
PADZZ	4310-008-9893	HEAD: fourth stage cylinder		EA	1							*	*	C-7	8
KDDZZ		WASHER, LOCK: fourth stage cylinder head screw MS122057 (96906)		EA	5				See Kit 5365-255-5605					C-7	9
KDDZZ		SCREW: fourth stage cylinder head 5833-1640 (33525)		EA	5				See Kit 5365-255-5605					C-7	10
PADZZ	4310-102-5564	PLATE: fourth stage valve 273050 (33525)		EA	1							*	*	C-7	11
KDDZZ		GASKET: fourth stage valve plate 247364 (33525)		EA	1				See Kit 5365-255-5605					C-7	12
KDDZZ		VALVE: fourth stage inlet 213181 (33525)		EA	1				See Kit 5365-255-5605					C-7	13
KDDZZ		SPRING: fourth stage inlet 245531 (33525)		EA	1				See Kit 5365-255-5605					C-7	14
PADZZ	4310-008-9894	CYLINDER AND PLUNGER ASSEMBLY: fourth stage 843913 (33525)		EA	1							*	*	C-7	15
XA----		PIN: fourth stage cylinder 214395 (33525)		1										C-7	16
XA----		CYLINDER: fourth stage 292079 (33525)		1										C-7	17
XA----		PLUNGER: fourth stage cylinder 277794 (33525)		1										C-7	18
KDDZZ		SHIM: fourth stage cylinder, .010 in 255136 (33525)		EA	V				See Kit 5365-255-5605					C-7	19
KDDZZ		SHIM: fourth stage cylinder, .005 in 255135 (33525)		EA	V				See Kit 5365-255-5605					C-7	20
KDDZZ		SHIM: fourth stage cylinder .003 in 255134 (33525)		EA	V				See Kit 5365-255-5605					C-7	21
KDDZZ		SPRING: third stage inlet 245821 (33525)		EA	1				See Kit 5365-255-5605					C-8	1
KDDZZ		VALVE: third stage inlet 246876 (33525)		EA	1				See Kit 5365-255-5605					C-8	2
KDDZZ		GASKET: third stage cylinder 247064 (33525)		EA	1				See Kit 5365-255-5605					C-8	3
KDDZZ		PLATE: third stage valve 272947 (33525)		EA	1				See Kit 5365-255-5605					C-8	4
KDDZZ		VALVE: third stage outlet 213384 (33525)		EA	1				See Kit 5365-255-5605					C-8	5



SECTION III

TM 5-4310-340-24

REPAIR PARTS FOR DIRECT SUPPORT, GENERAL SUPPORT, AND DEPOT MAINTENANCE															
(1) SMR CODE	(2) FEDERAL STOCK NUMBER	(3) DESCRIPTION Reference Number & Mfr. Code Usable on Code		(4) UNIT OF MEAS	(5) QTY INC IN UNIT	(6) 30 DAY DS MAINTENANCE ALLOWANCE			(7) 30 DAY GS MAINTENANCE ALLOWANCE			(8) 1 YR ALW PER 100 EQUIP CNTGCY	(9) DEPOT MAINT ALW PER 100 EQUIP	(10) ILLUSTRATION	
						(a) 1-20	(b) 21-50	(c) 51-100	(a) 1-20	(b) 21-50	(c) 51-100			(a) FIGURE NO.	(b) ITEM NO.
KDDZZ		SPRING: third stage outlet 213386 (33525)		EA	2				See Kit 5365-255-5605					C-8	6
KDDZZ		SPACER: third stage outlet 246763 (33525)		EA	1				See Kit 5365-255-5605					C-8	7
XA----		STOP: third stage valve 245808 (33525)		1										C-8	8
KDDZZ		GASKET: third stage head 213360 (33525)		EA	1				See Kit 5365-255-5605					C-8	9
KDDZZ		PACKING, PREFORMED: third stage head 6347-0020 (33525)		EA	1				See Kit 5365-255-5605					C-8	10
PADZZ	4310-107-1063	HEAD ASSEMBLY: third stage cylinder 842565 (33525)		EA	1							*	*	C-8	11
XA----		HEAD: third stage cylinder 275556 (33525)		I										C-8	12
KDDZZ		WASHER, LOCK: third stage head screw MS122055 (96906)		EA	4				See Kit 5365-255-5605					C-8	13
KDDZZ		SCREW: third stage head 5833-1034 (33525)		EA	4				See Kit 5365-255-5605					C-8	14
PADZZ	5315-009-7761	PIN: third stage head 247237 (33525)		EA	1							*	*	C-8	15
PADZZ	4310-781-4664	CYLINDER: third stage 274799 (33525)		EA	1							*	*	C-8	16
KDDZZ		RING: third stage piston 249337 (33525)		EA	4				See Kit 5365-255-5605					C-8	17
KDDZZ		EXPANDER: third stage piston rings 249336 (33525)		EA	2				See Kit 5365-255-5605					C-8	18
PADZZ	4310-781-4659	PISTON: third stage 275044 (33525)		EA	1							*	*	C-8	19
KDDZZ		SHIM: third stage cylinder, .010 in 255136 (33525)		EA	V				See Kit 5365-255-5605					C-8	20
KDDZZ		SHIM: third stage cylinder, .005 in 255135 (33525)		EA	V				See Kit 5365-255-5605					C-8	21
KDDZZ		SHIM: third stage cylinder .003 in 255134 (33525)		EA	V				See Kit 5365-255-5605					C-8	22
KDDZZ		PACKING, PREFORMED: third stage cylinder 5729-0912 (33525)		EA	1				See Kit 5365-255-5605					C-8	23
PADZZ	1040-972-2321	PLATE: second stage valve 272265 (33525)		EA	1				See Kit 5365-255-5605			*	*	C-9	1
KDDZZ		VALVE: second stage inlet 213167 (33525)		EA	1				See Kit 5365-255-5605					C-9	2
KDDZZ		SPRING: second stage inlet valve 245516 (33525)		EA	1				See Kit 5365-255-5605					C-9	3

SECTION III

TM 5-4310-340-24

REPAIR PARTS FOR DIRECT SUPPORT, GENERAL SUPPORT, AND DEPOT MAINTENANCE															
(1) SMR CODE	(2) FEDERAL STOCK NUMBER	(3) DESCRIPTION Reference Number & Mfr. Code Usable on Code		(4) UNIT OF MEAS	(5) QTY INC IN UNIT	(6) 30 DAY DS MAINTENANCE ALLOWANCE			(7) 30 DAY GS MAINTENANCE ALLOWANCE			(8) 1 YR ALW PER 100 EQUIP CNTGCT	(9) DEPOT MAINT ALW PER 100 EQUIP	(10) ILLUSTRATION	
						(a) 1-20	(b) 21-50	(c) 51-100	(a) 1-20	(b) 21-50	(c) 51-100			(a) FIGURE NO.	(b) ITEM NO.
KDDZZ		SPACER: second stage cylinder 213170 (33525)		EA	1			See Kit 5365-255-5605						C-9	4
KDDZZ		SHIM: second stage cylinder, .003 in 255121 (33525)		EA	V			See Kit 5365-255-5605						C-9	5
KDDZZ		SHIM: second stage cylinder, .005 in 255122 (33525)		EA	V			See Kit 5365-255-5605						C-9	6
KDDZZ		SHIM: second stage cylinder, .010 in 255123 (33525)		EA	V			See Kit 5365-255-5605						C-9	7
PADZZ	1040-974-3740	PLUNGER ASSEMBLY: second stage 873732 (33525)		EA	1	*					*	*		C-9	8
KDDZZ		VALVE: second stage outlet 245835 (33525)		EA	1			See Kit 5365-255-5605						C-9	9
KDDZZ		SPRING: second stage outlet 245836 (33525)		EA	1			See Kit 5365-255-5605						C-9	10
XA----		STOP: second stage valve 245837 (33525)		EA	1									C-9	11
KDDZZ		GASKET: second stage head 213399 (33525)		EA	1			See Kit 5365-255-5605						C-9	12
KDDZZ		GASKET: second stage outlet 213169 (33525)		EA	1			See Kit 5365-255-5605						C-9	13
PADZZ	1040-976-8981	HEAD ASSEMBLY: second stage 842294 (33525)		EA	1						*	*		C-9	14
XA----		HEAD: second stage 272264 (33525)		EA	1									C-9	15
KDDZZ		WASHER, LOCK: second stage head screw MS122057 (96906)		EA	4			See Kit 5365-255-5605						C-9	16
KDDZZ		SCREW: second stage head 5833-1614 (33525)		EA	4			See Kit 5365-255-5605						C-9	17
XBFZZ		SCREW: oil manifold 1264-2424 (33525)		EA	1									C-10	1
XBFZZ		SCREW: first stage head 5833-1014 (33525)		EA	6									C-10	2
XBFZZ		WASHER, LOCK: first stage head screw MS122055 (96906)		EA	6									C-10	3
PAFZZ	4310-008-9898	HEAD: first stage cylinder 292084 (33525)		EA	1	*	*	*	*	*	*	*	*	2C-10	4
PCFZZ	5330-008-7915	PACKING, PREFORMED: first stage head 5729-0137 (33525)		EA	1	*	*	*	*	*	*	*	*	C-10	5
XBDZZ		PLATE: support, first stage cylinder 874908 (33525)		EA	1									C-10	6
PADZZ		NUT: first stage valve 27Fn-428 (56878)		EA	1						*	*		C-10	7

SECTION III

TM 5-4310-340-24

REPAIR PARTS FOR DIRECT SUPPORT, GENERAL SUPPORT, AND DEPOT MAINTENANCE																	
(1) SMR CODE	(2) FEDERAL STOCK NUMBER	(3) DESCRIPTION Reference Number & Mfr. Code Usable on Code		(4) UNIT OF MEAS	(5) QTY INC IN UNIT	(6) 30 DAY DS MAINTENANCE ALLOWANCE			(7) 30 DAY GS MAINTENANCE ALLOWANCE			(8) 1 YR ALW PER 100 EQUIP CNTGCT	(9) DEPOT MAINT ALW PER 100 EQUIP	(10) ILLUSTRATION			
						(a) 1-20	(b) 21-50	(c) 51-100	(a) 1-20	(b) 21-50	(c) 51-100			(a) FIGURE NO.	(b) ITEM NO.		
PADZZ	5310-167-0835	WASHER, FLAT: first stage valve AN960-416L (88044)		EA	1							*	*	C-10	8		
KDDZZ		FILTER: first stage air Inlet 874907 (33525)		EA	1										C-10	9	
KDDZZ		SEAL: first stage head 213184 (33525)		EA	1										C-10	10	
KDDZZ		SPRING: first stage outlet 213174 (33525)		EA	3										C-10	11	
KDDZZ		VALVE: first stage outlet 213173 (33525)		EA	1										C-10	12	
KDDZZ		SEAT: first stage outlet valve 247069 (33525)		EA	1										C-10	13	
KDDZZ		GASKET: first stage valve seat 214335 (33525)		EA	1										C-10	14	
XBDZZ		SCREW: first stage valve seat 247067 (33525)		EA	1										C-10	15	
XA----		PLATE: first stage valve 273963 (33525)		EA	1										C-10	16	
KDDZZ		PACKING, PREFORMED: first stage cylinder 5729-0040 (33525)		EA	1										C-10	17	
KDDZZ		VALVE: first stage inlet 250606 (33525)		EA	1										C-10	18	
KDDZZ		SPRING: first stage inlet 245523 (33525)		EA	1										C-10	19	
KDDZZ		SPACER: first stage valve plate 248232 (33525)		EA	1										C-10	20	
KDDZZ		SHIM: first stage valve,.003 in 255111 (33525) l		EA	V										C-10	21	
KDDZZ		SHIM: first stage valve.005 In 255112 (33525)		EA	V										C-10	22	
KDDZZ		SHIM: first stage valve, .010 in 255113 (33525)		EA	V										C-10	23	
KDDZZ		RING: compression, first stage piston 248231 (33525)		EA	2										C-10	24	
PADZZ		4310-781-4706	PISTON: first stage 290864 (33525)		EA	1							*	*	C-10	25	
KDDZZ			RING: piston pin retaining 203691 (33525)		EA	2										C-10	26
KDDZZ			PACKING, PREFORMED: piston pin access plug 5729-0910 (33525)		EA	1										C-10	27
XBDZZ	PLUG: piston pin access AN814-10ODL (33525)		EA	1										C-10	28		

(1) SMR CODE	(2) FEDERAL STOCK NUMBER	(3) DESCRIPTION Reference Number & Mfr. Code Usable on Code		(4) UNIT OF MEAS	(5) QTY INC IN UNIT	(6) 30 DAY DS MAINTENANCE ALLOWANCE			(7) 30 DAY GS MAINTENANCE ALLOWANCE			(8) 1 YR ALW PER 100 EQUIP CNTGCT	(9) DEPOT MAINT ALW PER 100 EQUIP	(10) ILLUSTRATION	
						(a) 1-20	(b) 21-50	(c) 51-100	(a) 1-20	(b) 21-50	(c) 51-100			(a) FIGURE NO.	(b) ITEM NO.
						KDDZZ		RING: lock, piston pin 206517 (33526)	EA	1					See Kit 5365-255-5605
KDDZZ		SHLM: piston pin 2036 (33525)	EA	1			See Kit 5365-255-5605							C-10	30
KDDZZ		SHIM: piston pin 205493 (33525)	EA	1			See Kit 5365-255-5605							C-10	31
KDDZZ		SHIM: piston pin	EA	2			See Kit 5365-255-5605							C-10	32
PADZZ	1040-970-8430	205494 (33525) PIN: piston 841727 (33525)	EA	1							*	*		C-10	33
PAOZZ	6680-009-3569	DIPSTICK: oil level indicating 292932 (33525)	EA	1	*	*	1	*	*1	*	*	*		C-10	34
PCOZZ	5330-009-0553	PACKING, PREFORMED: oil level dipstick (1), oil fill plug (1) 5729-0906 (33525)	EA	2	*	*	1	**	1	*	*	*		C-10	35
XBFZZ		ADAPTER: oil fill and dipstick tube 255201 (33525)	EA	1										C-10	36
PCFZZ	5330-009-0565	PACKING, PREFORMED: oil fill and dipstick tube 5729-0014 (33525)	EA	1	*	*	*	*	*	*	*	*	*	C-10	37
PAOZZ		PLUG: oil fill 258502 (33525)	EA	1	*	*	*	*	*	*	*	*	*	C-10	38
XBFZZ		MANIFOLD ASSEMBLY: oil fill and dipstick 896060 (33525)	EA	1										C-10	39
XBFZZ		WASHER, FLAT: oil manifold screw 1159-2400 (33525)	EA	1										C-10	40
XBFZZ		WASHER, LOCK: oil manifold screw 5652-2400 (33525)	EA	1										C-10	41
PAFZZ	4310-134-8909	ADAPTER: crankcase 894794 (33525)	EA	1	*	*	1	*	*	1	*	*	*	C-11	1
PCFZZ	5330-008-7913	PACKING, PREFORMED: crankcase adapter 5729-0149 (33525)	EA	1	*	*	1	*	*	1	*	*	*	C-11	2
XBFZZ		TEE: check valve 258501 (33525)	EA	1										C-11	3
PCFZZ	5330-009-0566	PACKING, PREFORMED: cheek valve (1), check valve tee (1) 5729-0904 (33525)	EA	2	*	*	*	*	*	*	*	*	*	C-11	4
PAFZZ	4820-008-9895	VALVE: check, blow-by 876035 (33525)	EA	1	*	*	*	*	*	*	*	*	*	C-11	5
XBDZZ		PLATE: oil pump backup 843914 (33525)	EA	1										C-11	6
KDDZZ		KEY: oil pump to crankshaft 256155 (33525)	EA	1			See Kit 5365-255-5605							C-11	7

(1) SMR CODE	(2) FEDERAL STOCK NUMBER	(3) DESCRIPTION Reference Number & Mfr. Code Usable on Code	(4) UNIT OF MEAS	(5) QTY INC IN UNIT	(6) 30 DAY DS MAINTENANCE ALLOWANCE			(7) 30 DAY GS MAINTENANCE ALLOWANCE			(8) 1 YR ALW PER 100 EQUIP CNTGCY	(9) DEPOT MAINT ALW PER 100 EQUIP	(10) ILLUSTRATION	
					(a) 1-20	(b) 21-50	(c) 51-100	(a) 1-20	(b) 21-50	(c) 51-100			(a) FIGURE NO.	(b) ITEM NO.
					PADZZ	4310-435-4403	GEROTOR: oil pump GA7284-1 and GA7284-2 (86329)	EA	1					
KDDZZ		RING: retaining, oil pump relief valve MS16625-37 (96906)	EA	1			See Kit 5365-255-5605						C-11	9
XBDZZ		PLUG: oil pump relief valve 276451 (33525)	EA	1									C-11	10
KDDZZ		PACKING, PREFORMED: oil pump relief 5729-0012 (33525)	EA	1			See Kit 5365-255-5605						C-11	11
KDDZZ		SHIM: oil pump relief valve 212853 (33525)	EA	6			See Kit 5365-255-5605						C-11	12
KDDZZ		SPRING: oil pump relief valve 206845 (33525)	EA	1			See Kit 5365-255-5605						C-11	13
PADZZ	1650-328-3725	GUIDE: oil pump relief valve 206844 (33525)	EA	1							*	*	C-11	14
KDDZZ		BALL: oil pump relief valve 206852 (33525)	EA	1			See Kit 5365-255-5605						C-11	15
PAFZZ	5330-008-9226	GASKET: oil pump housing 251718 (33525)	EA	1	*	*	1	*	*	1	*	*	C-11	16
XBDZZ		HOUSING: oil pump 292077 (33525)	EA	1									C-11	17
PCFZZ	5330-008-9194	SEAL: oil, crankshaft, front 523633 (80201)	EA	1	*	*	1	*	*	1	*	*	C-11	18
KDDZZ		WASHER, SEAL: oil pump housing screw 6052-0800 (33525)	EA	3			See Kit 5365-255-5605						C-11	19
PADZZ	5310-685-3744	WASHER, FLAT: oil pump housing screw AN960C8 (88044)	EA	3							*	*	C-11	20
PADZZ		SCREW: oil pump housing STSW-0816 (11828)	EA	3							*	*	C-11	21
PCFZZ	5330-008-7914	PACKING, PREFORMED: oil pickup strainer 5729-0908 (33525)	EA	1	*	*	1	*	*	1	*	*	C-11	22
PAFZZ	4710-009-2173	STRAINER: oil pickup 843956 (33525)	EA	1	*	*	1	*	*	1	*	*	C-11	23
PAFZZ	4730-008-9872	FITTING: oil sump 277778 (33525)	EA	1	*	*	1	*	*	1	*	*	C-11	24
XBDZZ		CRANKCASE: compressor 894799 (33525)	EA	1									C-11	25
KDDZZ		BEARING: crankshaft (fan end) 245733 (33525)	EA	1			See Kit 5365-255-5605						C-11	26
PADZZ	4310-008-9897	CRANKSHAFT: compressor 843916 (33525)	EA	1							*	*	C-11	27
PADZZ	4310-008-9896	SPLINE ASSEMBLY 876009 (33525)	EA	1							*	*	C-11	28

(1) SMR CODE	(2) FEDERAL STOCK NUMBER	(3) DESCRIPTION Reference Number & Mfr. Code Usable on Code	(4) UNIT OF MEAS	(5) QTY INC IN UNIT	(6) 30 DAY DS MAINTENANCE ALLOWANCE			(7) 30 DAY GS MAINTENANCE ALLOWANCE			(8) 1 YR ALW PER 100 EQUIP CNTGCY	(9) DEPOT MAINT ALW PER 100 EQUIP	(10) ILLUSTRATION	
					(a) 1-20	(b) 21-50	(c) 51-100	(a) 1-20	(b) 21-50	(c) 51-100			(a) FIGURE NO.	(b) ITEM NO.
KDDZZ		RING: spline retaining 5008-125 (79136)	EA	1			See Kit 5365-255-5605						C-11	29
KDDZZ		BEARING: crankshaft, rear (adapter end) 245734 (33525)	EA	1			See Kit 5365-255-5605						C-11	30
XBFZZ		WAVEWASHER: rear seal to rear bearing 245297 (33525)	EA	1									C-11	31
PCFZZ	5330-008-9196	SEAL: oil, crankshaft, rear 523632 (80201)	EA	1	*	*	1	*	*	1	*	*	C-11	32
PADZZ	1650-706-1863	KEYSTONE ASSEMBLY: crankshaft 872371 (33525)	EA	1							*	*	C-11	33
XA----		ROLLPIN: keystone 5206-6524 (33525)		1									C-11	34
XA----		FORK: keystone 242703 (33525)		1									C-11	35
XA----		ROLL PIN: keystone 5206-6324 (33525)		1									C-11	36
XA----		WEDGE: keystone 206527 (33525)		1									C-11	37
PAFZZ		RING: backup, cheek valve tee 5475-0400 (335253)	EA	1	*	*	*	*	*	*	*	*	C-11	38
XBFZZ		NUT: check valve tee 5811-0403 (33525)	EA	1									C-11	39
PAFZZ	5310-812-3373	WASHER, LOCK: crankcase adapter screw MS122057 (96906)	EA	4	*	*	*	*	*	*	*	*	C-11	40
PAFZZ		SCREW: crankcase adapter 1264-1612 (33525)	EA	4	*	*	*	*	*	*	*	*	C-11	41
PADZZ	5365-255-5605	OVERHAUL Kit 804535 (33525)	EA	1							*	*		
		1- PACKING											C-7	1
		2- SEAL											C-7	2
		1- VALVE											C-7	3
		1- SPRING											C-7	4
		1- PIN											C-7	5
		1- RING											C-7	7
		5- WASHER											C-7	9
		5- SCREW											C-7	10
		1- GASKET											C-7	12
		1- VALVE											C-7	13
		1- SPRING											C-7	14

(1) SMR CODE	(2) FEDERAL STOCK NUMBER	(3) DESCRIPTION	(4) UNIT OF MEAS	(5) QTY INC IN UNIT	(6) 30 DAY DS MAINTENANCE ALLOWANCE			(7) 30 DAY GS MAINTENANCE ALLOWANCE			(8) 1 YR ALW PER 100 EQUIP CNTGCY	(9) DEPOT MAINT ALW PER 100 EQUIP	(10) ILLUSTRATION	
					(a) 1-20	(b) 21-50	(c) 51-100	(a) 1-20	(b) 21-50	(c) 51-100			(a) FIGURE NO.	(b) ITEM NO.
		3- SHIM											C-7	19
		1- SHIM											C-7	20
		3- SHIM											C-7	21
		1- SPRING											C-8	1
		1- VALVE											C-8	2
		1- GASKET											C-8	3
		1- PLATE											C-8	4
		1- VALVE											C-8	5
		2- SPRING											C-8	8
		1- SPACER											C-8	7
		1- GASKE T											C-8	9
		1- PACKING											C-8	10
		4- WASHER											C-8	13
		4- SCREW											C-8	14
		4- RING											C-8	17
		2- EXPANDER											C-8	18
		2- SHIM											C-8	20
		1- SHIM											C-8	21
		2- SHIM											C-8	22
		1- PACKING											C-8	23
		1- VALVE											C-9	2
		1- SPRING											C-9	3
		1- SPACER											C-9	4
		1- SHIM											C-9	5
		1- SHIM											C-9	6
		2- SHIM											C-9	7
		1- VALVE											9	9
		1- SPRING												10
		1- GASKET											C-9	12
		1- GASKET											C-9	13
		4- WASHER											C-9	16
		4- SCREW											C-9	17
		6- SCREW											C-10	1

(1) SMR CODE	(2) FEDERAL STOCK NUMBER	(3) DESCRIPTION	(4) UNIT OF MEAS	(5) QTY INC IN UNIT	(6) 30 DAY DS MAINTENANCE ALLOWANCE			(7) 30 DAY GS MAINTENANCE ALLOWANCE			(8) 1 YR ALW PER 100 EQUIP CNTGCTY	(9) DEPOT MAINT ALW PER 100 EQUIP	(10) ILLUSTRATION	
					(a) 1-20	(b) 21-50	(c) 51-100	(a) 1-20	(b) 21-50	(c) 51-100			(a) FIGURE NO.	(b) ITEM NO.
		6- WASHER											C-10	3
		1- PACKING											C-10	5
		1- FILTER											C-10	9
		1- SEAL											C-10	10
		3- SPRING											C-10	11
		1- VALVE											C-10	12
		1- SEAT											C-10	13
		1- GASKET											C-10	14
		1- PACKING											C-10	17
		1- VALVE											C-10	18
		1- SPRING											C-10	19
		1- SPACER											C-10	20
		2- SHIM											C-10	21
		2- SHIM											C-10	22
		2- SHIM											C-10	23
		2- RING											C-10	24
		1- RING											C-10	26
		1- PACKING											C-10	27
		1- RING											C-10	29
		1- SHIM											C-10	30
		1- SHIM											C-10	31
		2- SHIM											C-10	32
		2- PACKING											C-10	35
		1- PACKING											C-10	37
		1- PACKING											C-11	2
		2- PACKING											C-11	4
		1- KEY											C-11	7
		1- RING											C-11	9
		1- PACKING											C-11	11
		6- SHIM											C-11	12
		1- SPRING											C-11	13
		1- BALL											C-11	15
		1- GASKET											C-11	16



(1) SMR CODE	(2) FEDERAL STOCK NUMBER	(3) DESCRIPTION	(4) UNIT OF MEAS	(5) QTY INC IN UNIT	(6) 30 DAY DS MAINTENANCE ALLOWANCE			(7) 30 DAY GS MAINTENANCE ALLOWANCE			(8) 1 YR ALW PER 100 EQUIP CNTGCY	(9) DEPOT MAINT ALW PER 100 EQUIP	(10) ILLUSTRATION	
					(a) 1-20	(b) 21-50	(c) 51-100	(a) 1-20	(b) 21-50	(c) 51-100			(a) FIGURE NO.	(b) ITEM NO.
		1- SEAL 3- WASHER 1- PACKING 1- BEARING 1- RING 1- BEARING 1- WAVEWASHER 1- SEAL 4- WASHER											C-11 18 C-11 19 C-11 22 C-11 26 C-11 29 C-11 30 C-11 31 C-11 32 C-11 40	

SECTION IV. SPECIAL TOOLS LIST

TM 5-4310-340-24

(1) SMR CODE	(2) FEDERAL STOCK NUMBER	(3) DESCRIPTION	(4) UNIT OF MEAS	(5) QTY INC IN UNIT	(6) 30 DAY DS MAINTENANCE ALLOWANCE			(7) 30 DAY GS MAINTENANCE ALLOWANCE			(8) 1 YR ALW PER 100 EQUIP CNTGCT	(9) DEPOT MAINT ALW PER 100 EQUIP	(10) ILLUSTRATION	
					(a) 1-20	(b) 21-50	(c) 51-100	(a) 1-20	(b) 21-50	(c) 51-100			(a) FIGURE NO.	(b) ITEM NO.
PEDZZ	4920-611-9632	GROUP 26- TOOLS AND TEST EQUIPMENT 2604 - SPECIAL TOOLS ADAPTER ASSEMBLY- compressor 871981 (33525)	EA	1							1	1	C-12	1
PEDZZ		GAGE, RING: keystone 209986 (33525)	EA	1							1	1	C-12	2
PEFZZ		TOOL: oil seal insertion 804419 (33525)	EA	1	1	1	1	1	1	1	1	1	C-12	3
PEDZZ		PIN, GUIDE: oil pump 804420 (33525)	EA	1							1	1	C-12	4
PEDZZ		GAGE, RING: keystone 209985 (33525)	EA	1							1	1	C-12	5
PEDZZ	4920-620-9159	SPINDLE, AIR keystone 209984 (33525)	EA	1							1	1	C-12	6
PEDZZ		SLEEVE, INSERTION: second stage 804421 (33525)	EA	1							1	1	C-12	7
PEDZZ		HOLDER: third stage valve plate 804424 (33525)	EA	1							1	1	C-12	8
PEDZZ		HOLDER: second stage valve plate 804425 (33525)	EA	1							1	1	C-12	9
PEDZZ		HOLDER: third and fourth stage head 804423 (33525)	EA	1							1	1	C-12	10
PEDZZ		NEST: fourth stage pin positioning 804422 (33525)	EA	1							1	1	C-12	11
PEDZZ		SLEEVE, INSERTION: first stage 804426 (33525)	EA	1							1	1	C-12	12
PEDZZ		FIXTURE: relief valve testing 876700 (33525)	EA	1							1	1	C-12	13
PEDZZ		FIXTURE: relief valve testing 876701 (33525)	EA	1							1	1	C-12	14
PEFZZ		FIXTURE fan assembly 890854 (33525)	EA	1	1	1	1	1	1	1	1	1	C-12	15

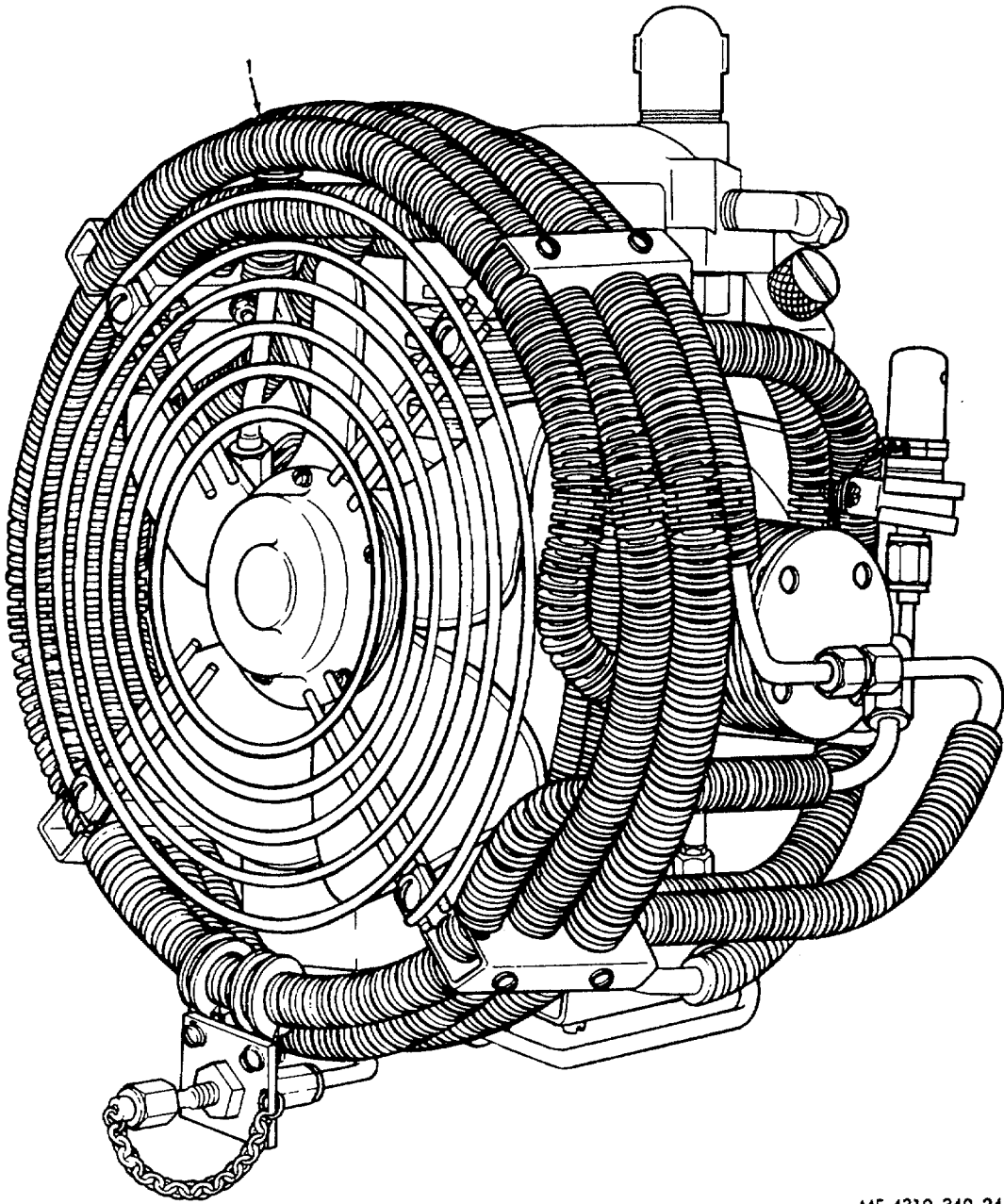

ME 4310-340-24/C-1

Figure C-1. Compressor assembly

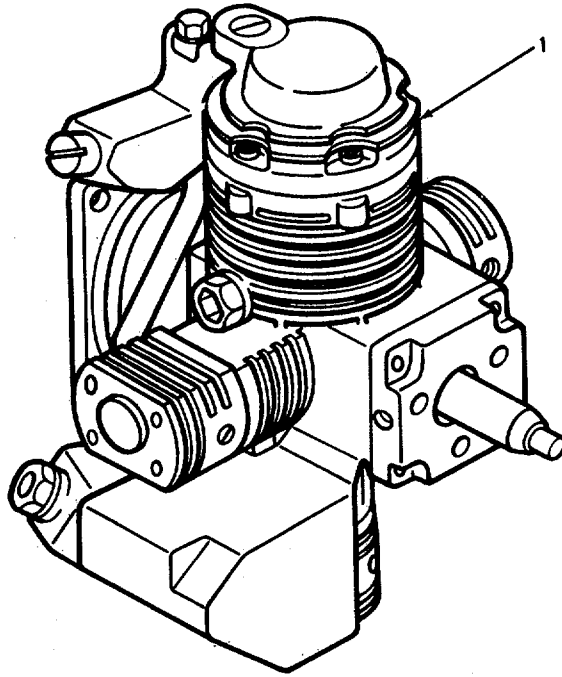

ME 4310-340-24/C-2

**Figure C-2. Basic compressor**

**C-21**

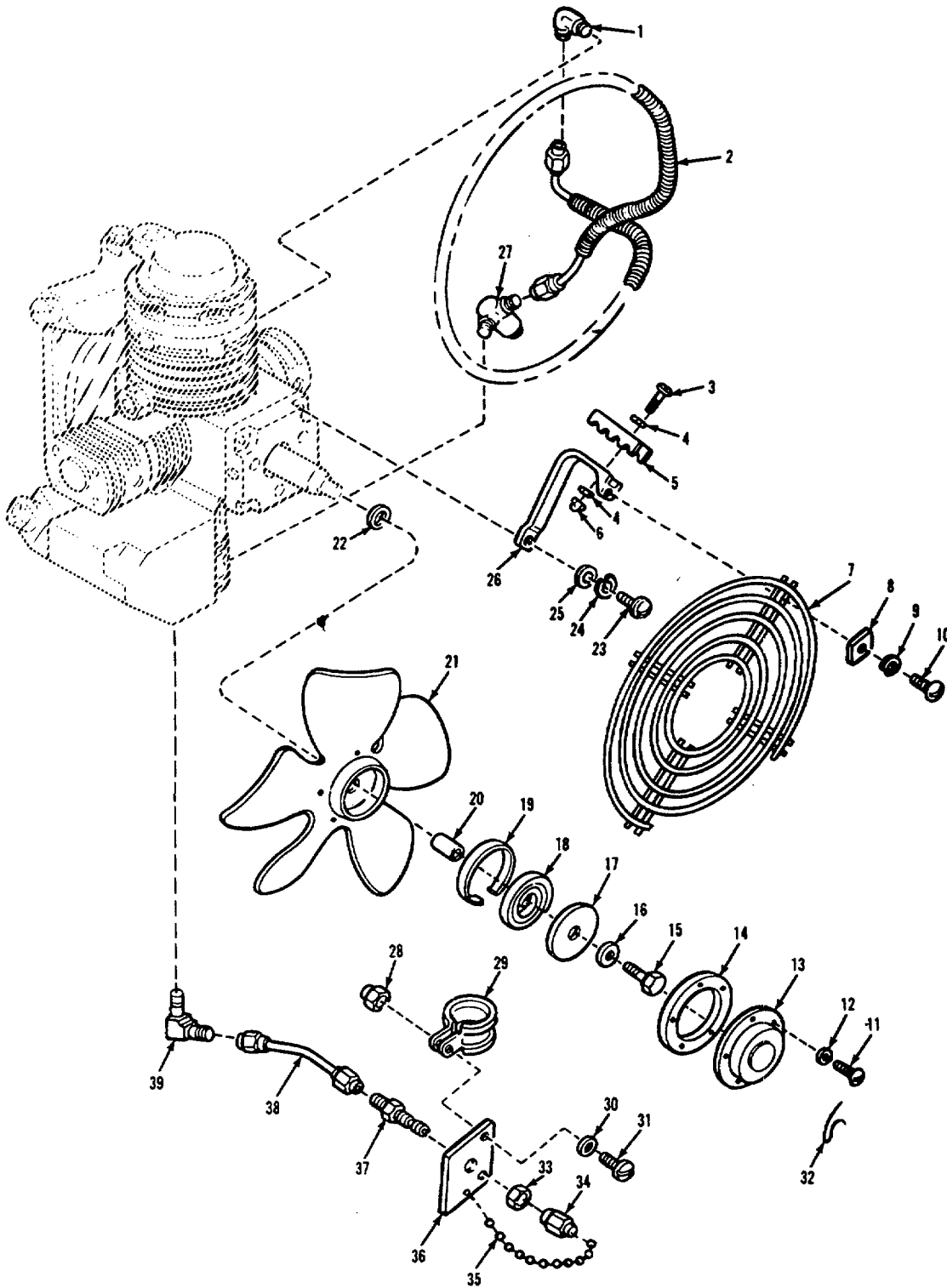

ME 4310-340-24/C-3

Figure C-3. Fan, fan guard, drain tube, third stage cooler, fan guard bracket, and related parts-exploded view.

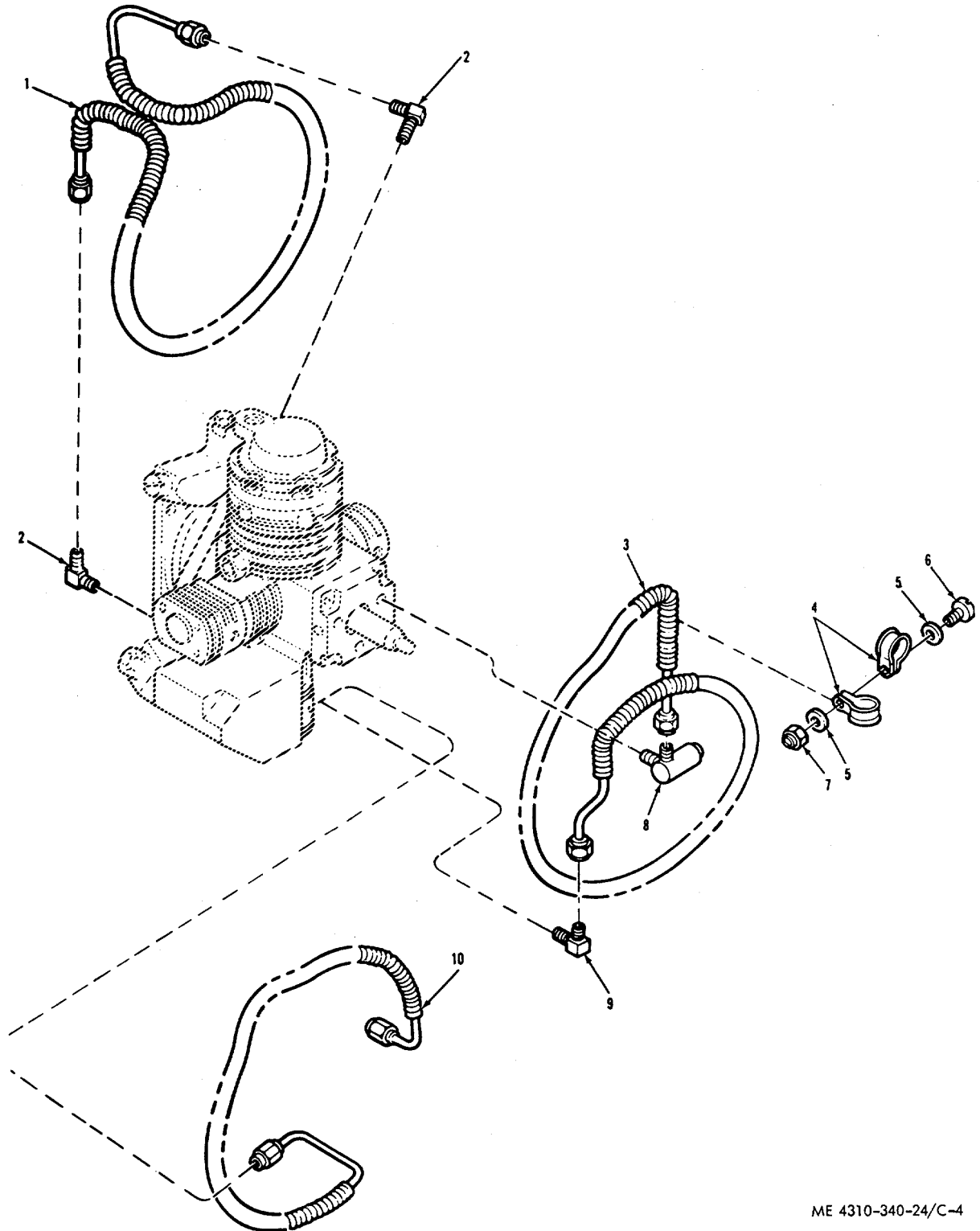

ME 4310-340-24/C-4

Figure C-4. Second stage cooler, first stage cooler, aftercooler tube, and related parts-  
exploded view

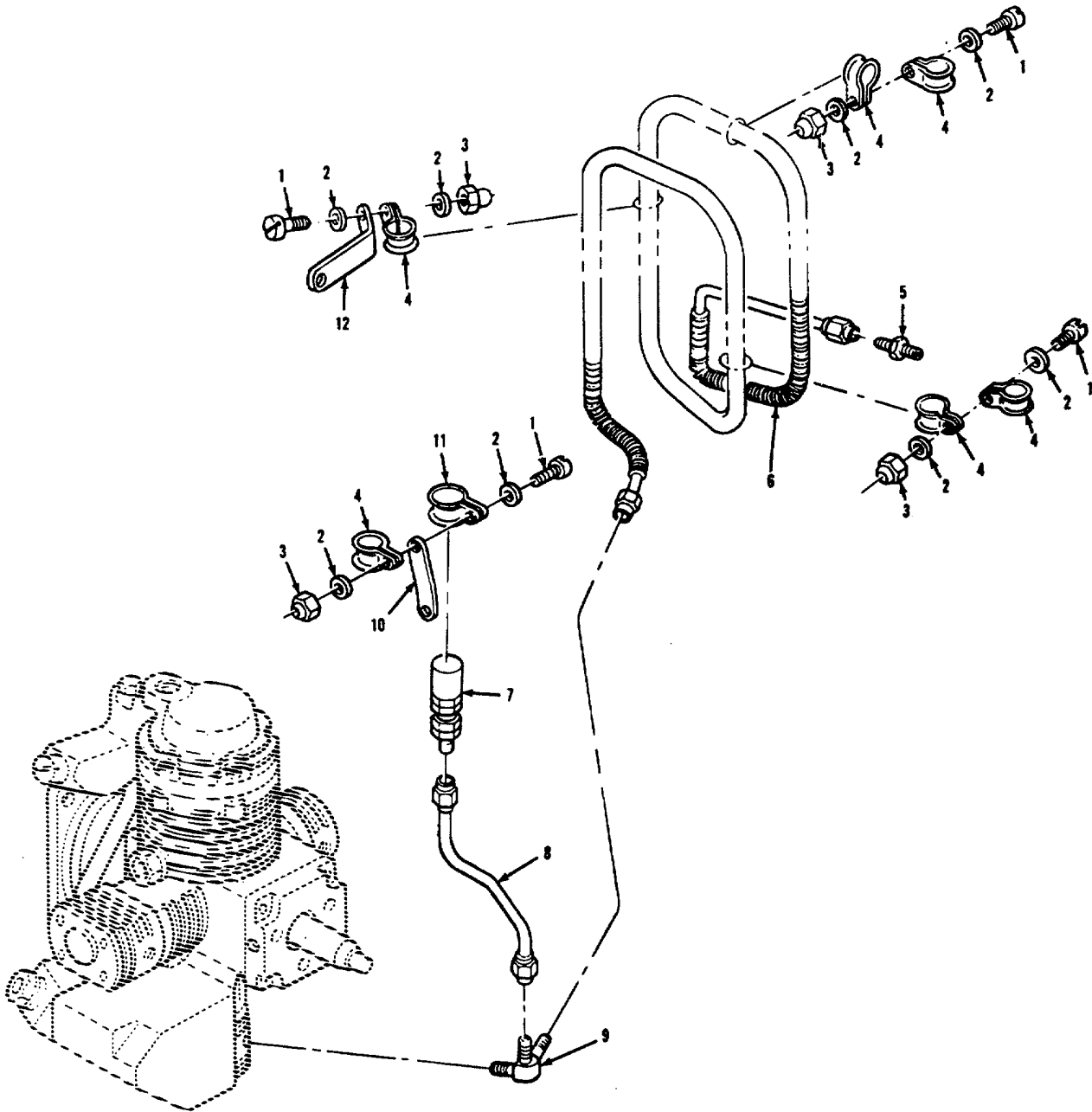

ME 4310-340-24/C-5

Figure C-5. Fourth state relief valve, relief valve tube, aftercooler, and related parts -- exploded view

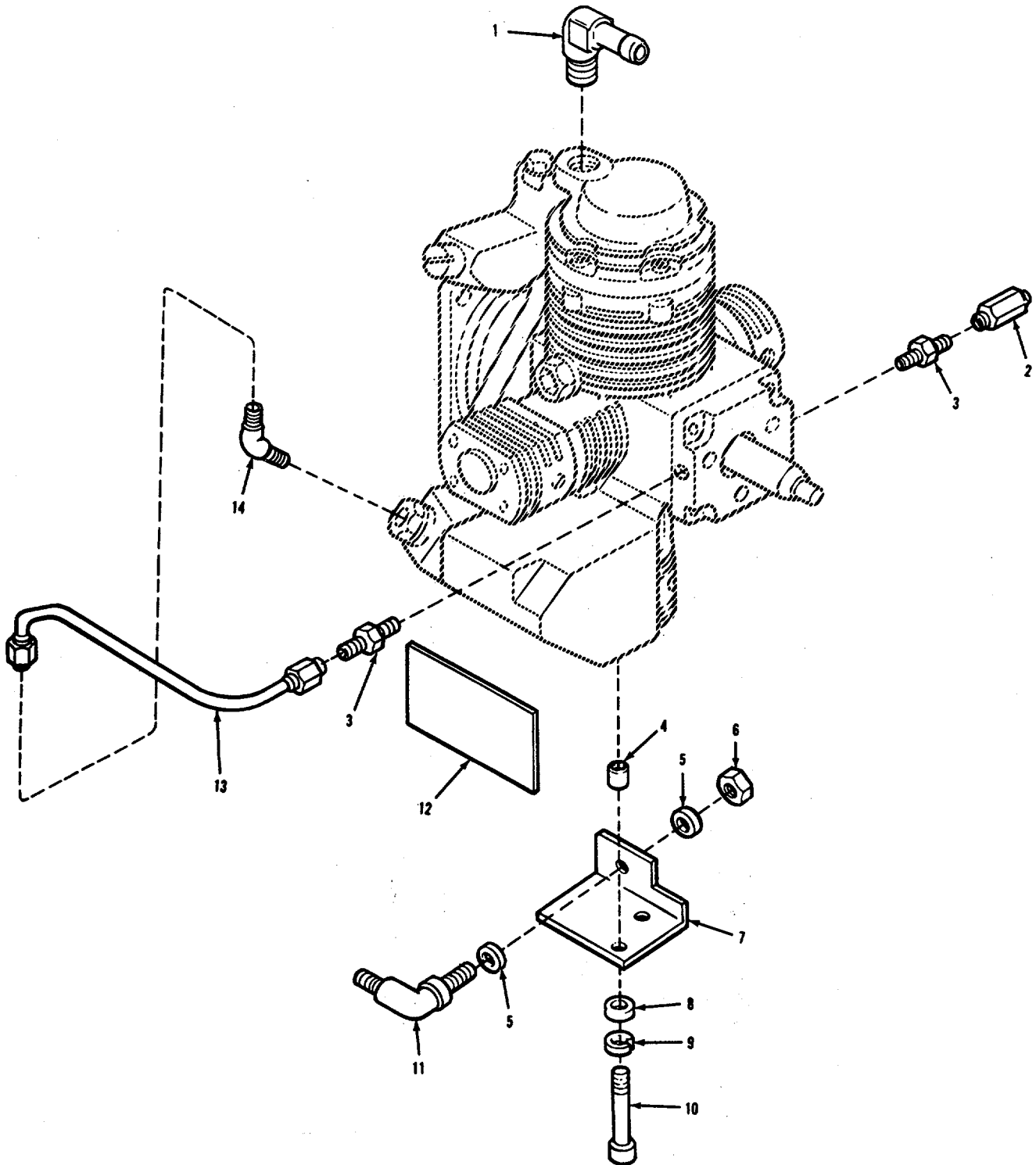

ME 4310-340-24/C-6

Figure C-6. Inlet oil tube, elbows, discharge bracket, fittings, unions, and related parts – exploded view



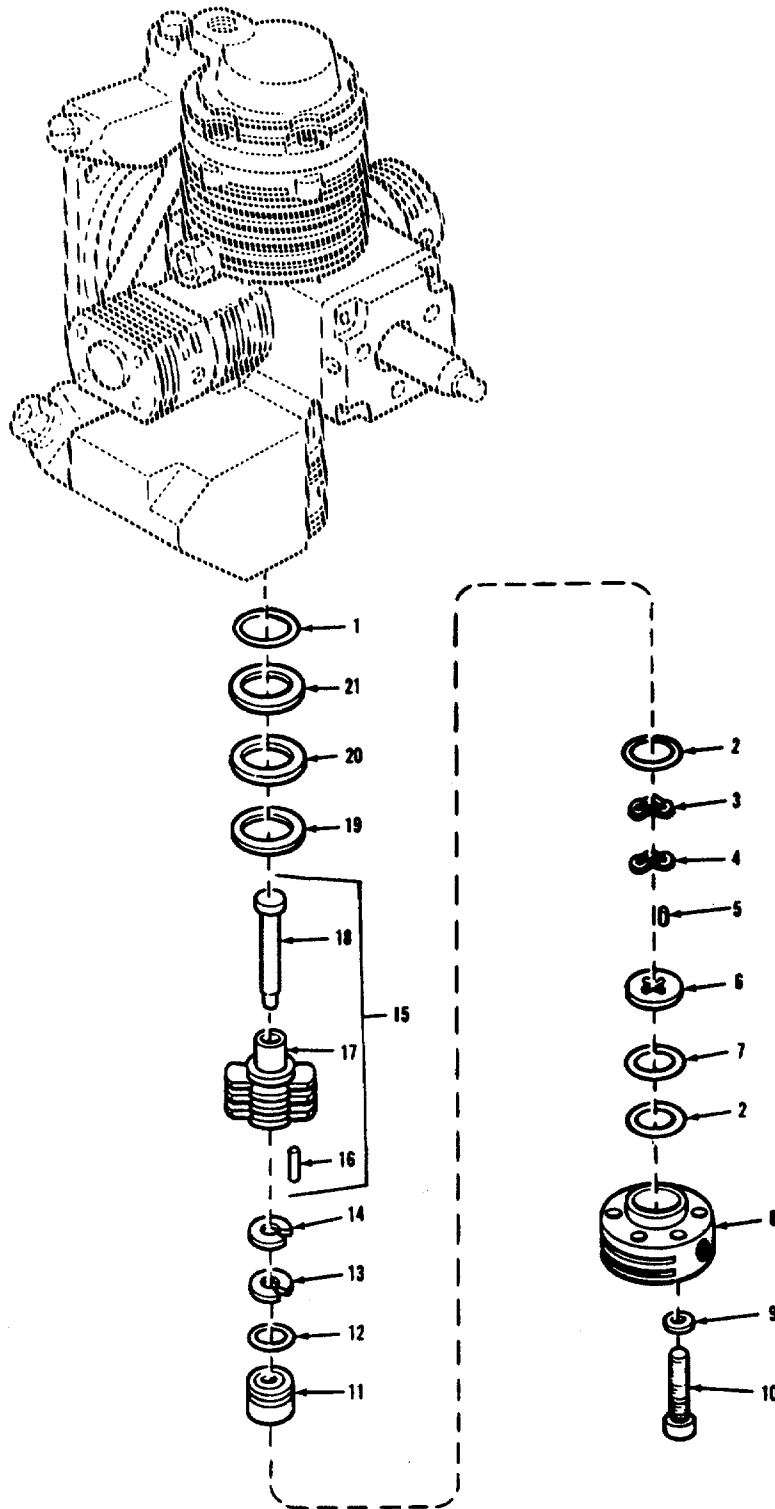

ME 4310-340-24/C-7

Figure C-7. Fourth stage cylinder, cylinder head and related parts – exploded view

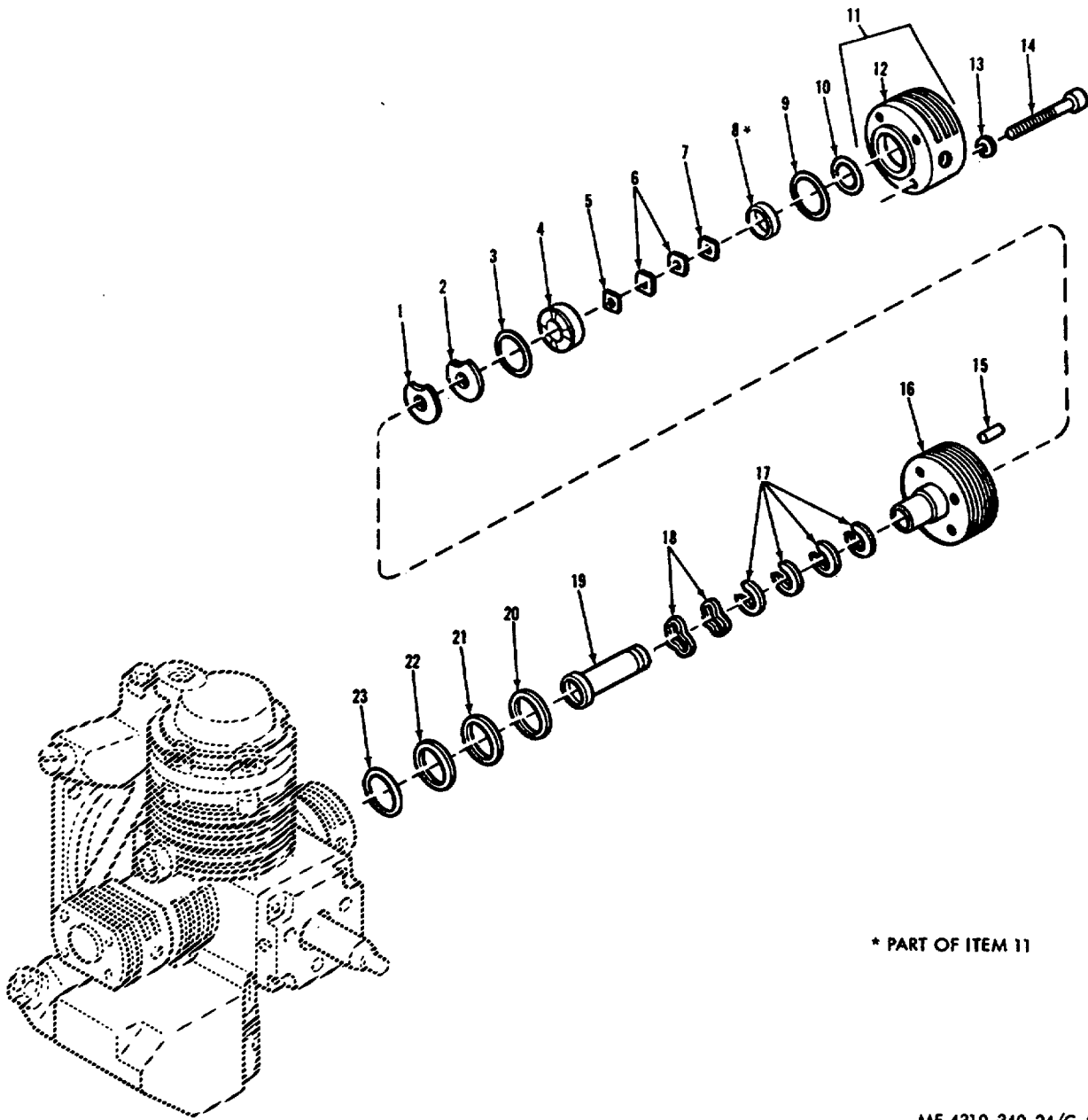

\* PART OF ITEM 11

ME 4310-340-24/C-8

Figure C-8. Third stage cylinder, cylinder head, and related parts – exploded view

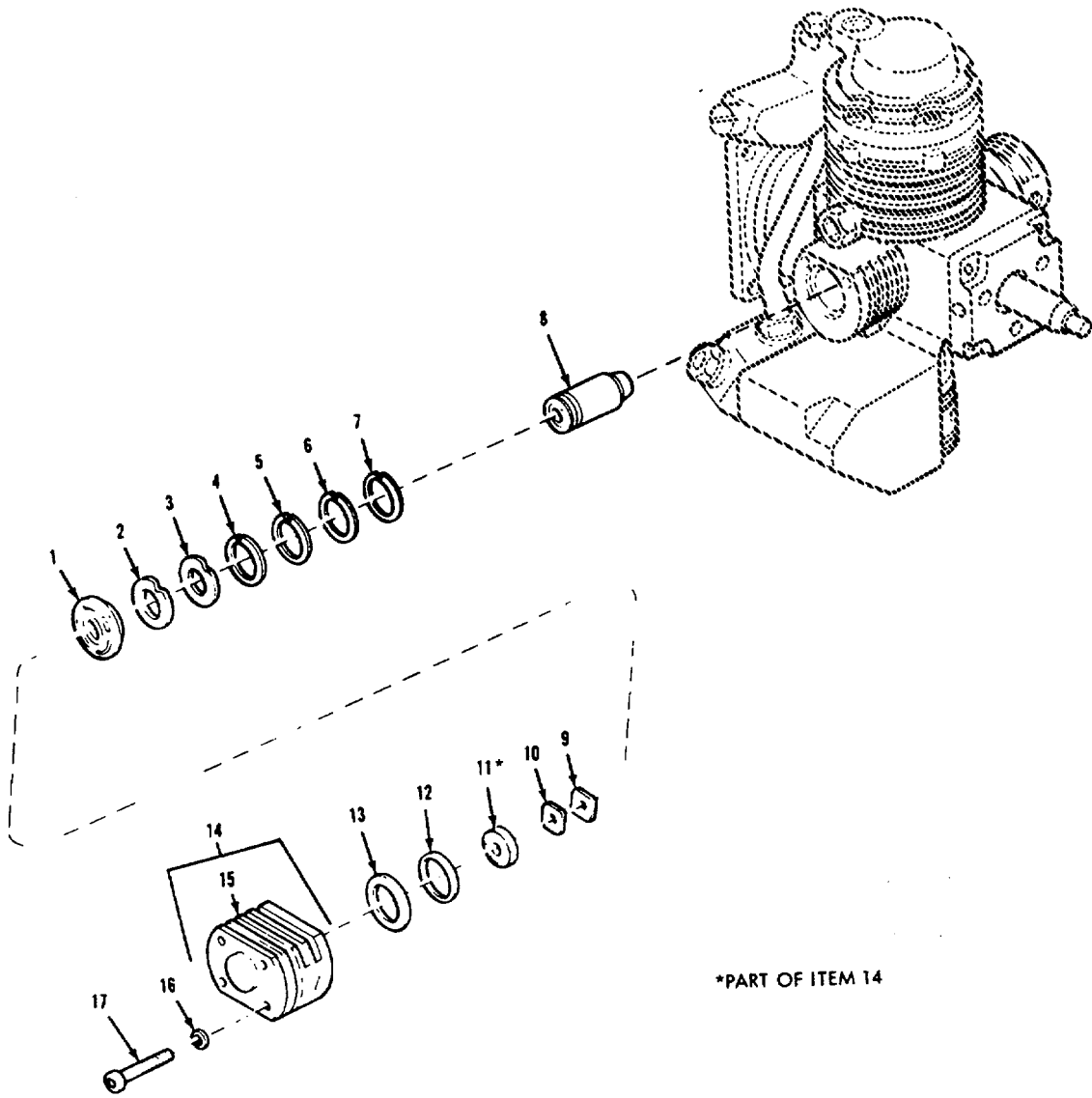

\*PART OF ITEM 14

ME 4310-340-24/C-9

Figure C-9. Second stage cylinder head and related parts – exploded view

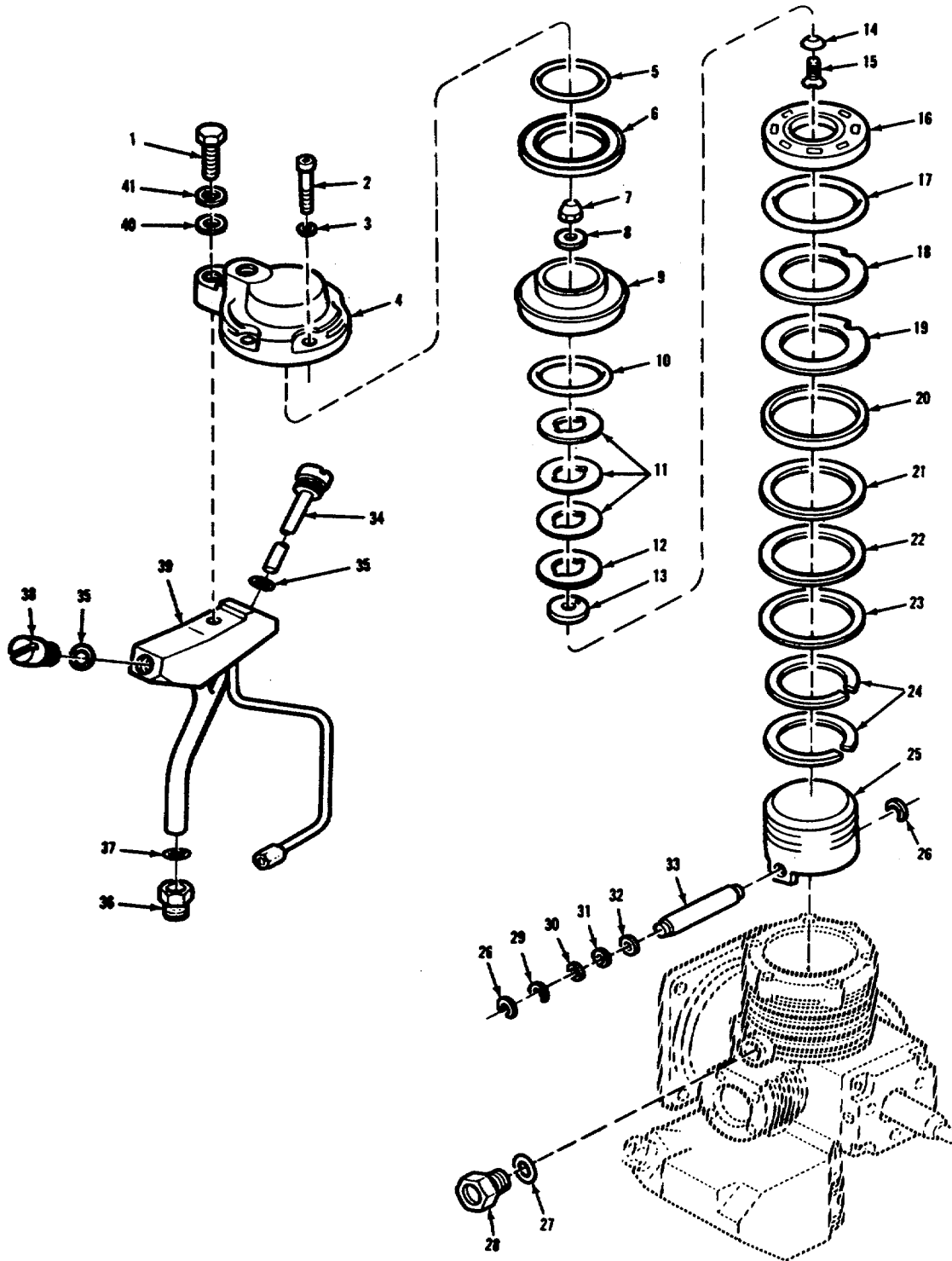

ME 4310-340-24/V-10

Figure C-10. First stage piston, first stage cylinder head, oil fill tube, dipstick, and related parts – exploded view

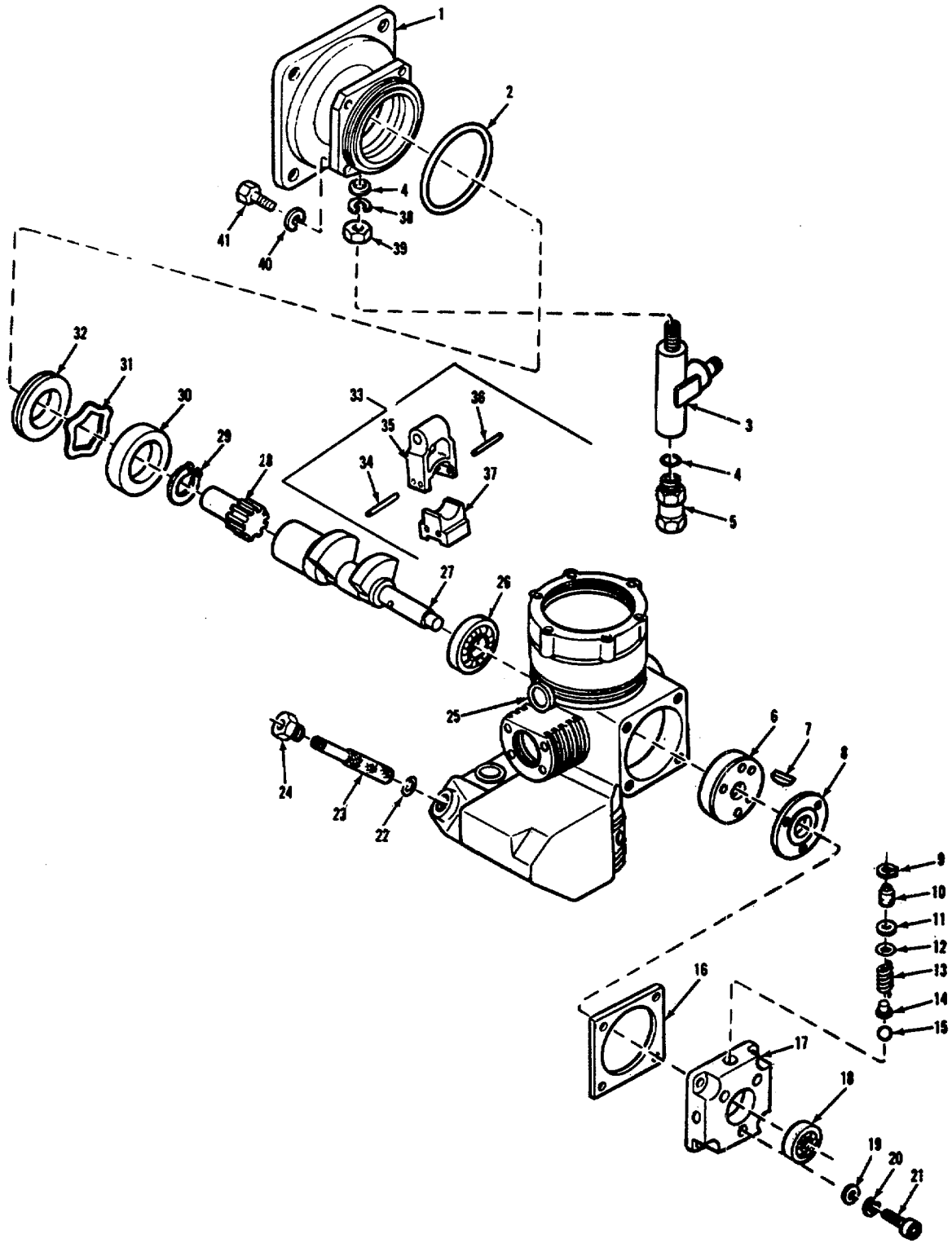

ME 4310-340-24/C-11

Figure C-11. Crankcase, crankshaft, oil pump, oil strainer, and related parts – exploded view

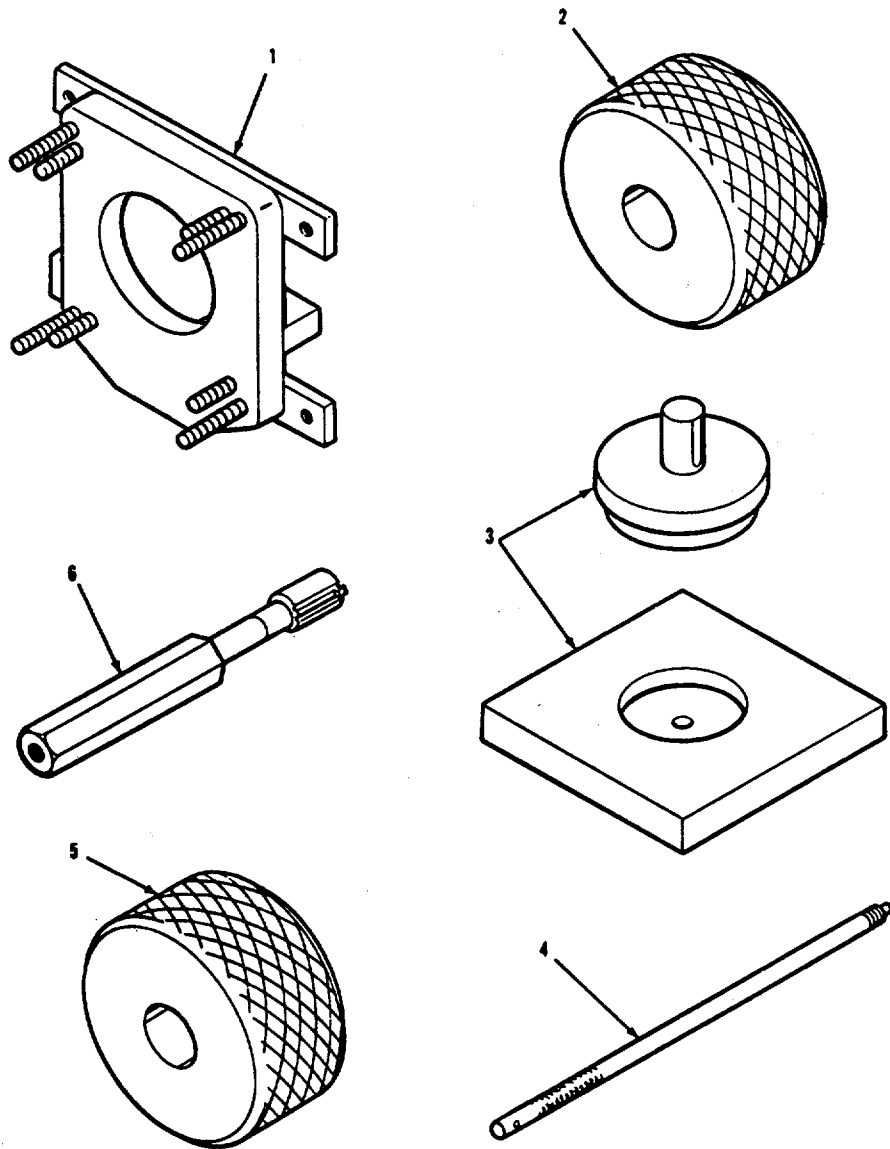

ME 4310-340-24/C12-①

Figure C-12. Special tools - (Sheet 1 of 4)

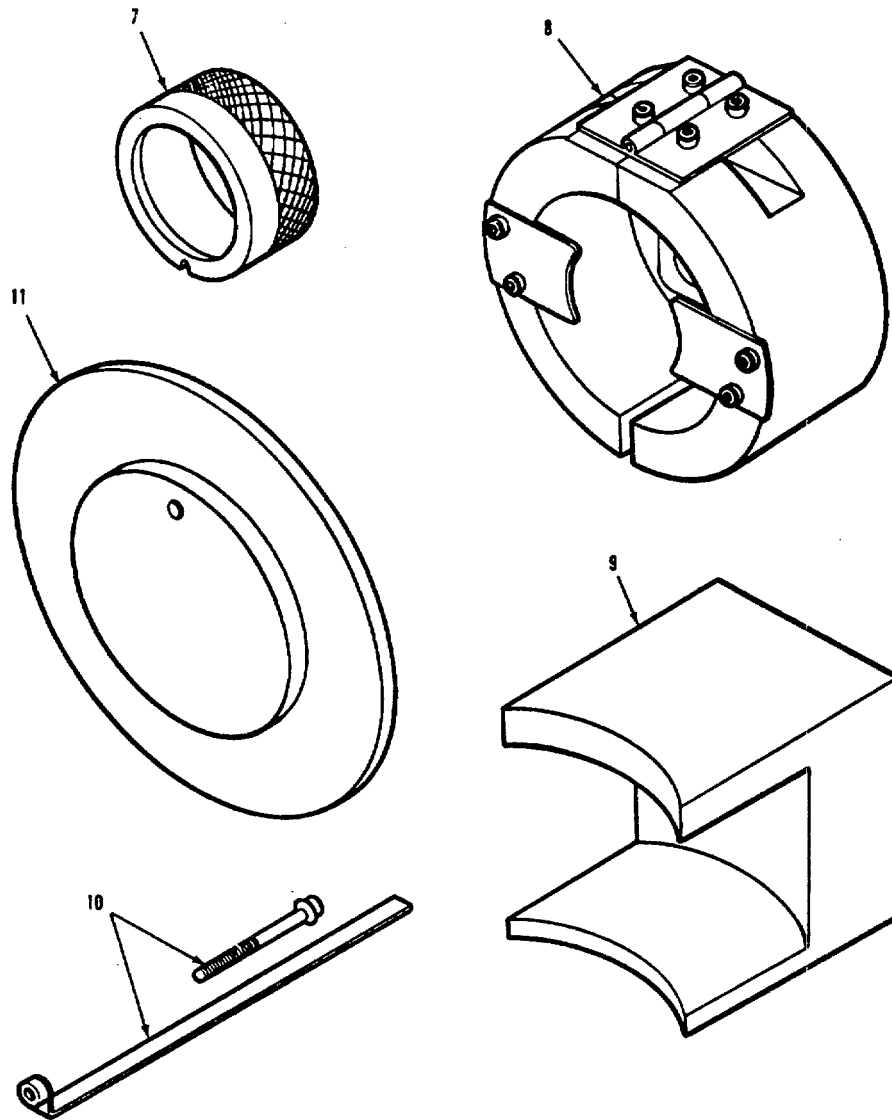

ME 4310-340-24/C12 ②

Figure C-12. Special tools - (Sheet 2 of 4)

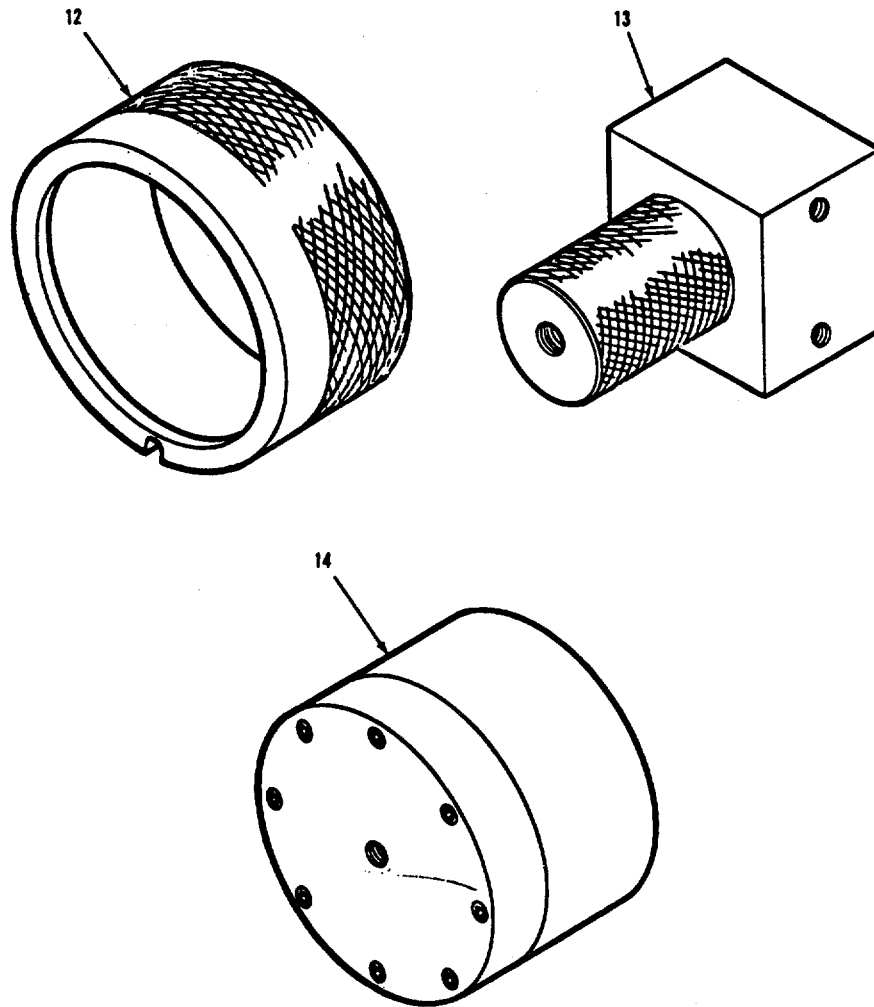

ME 4310-340-24/C12 ③

Figure C-12. Special tools - (Sheet 3 of 4)



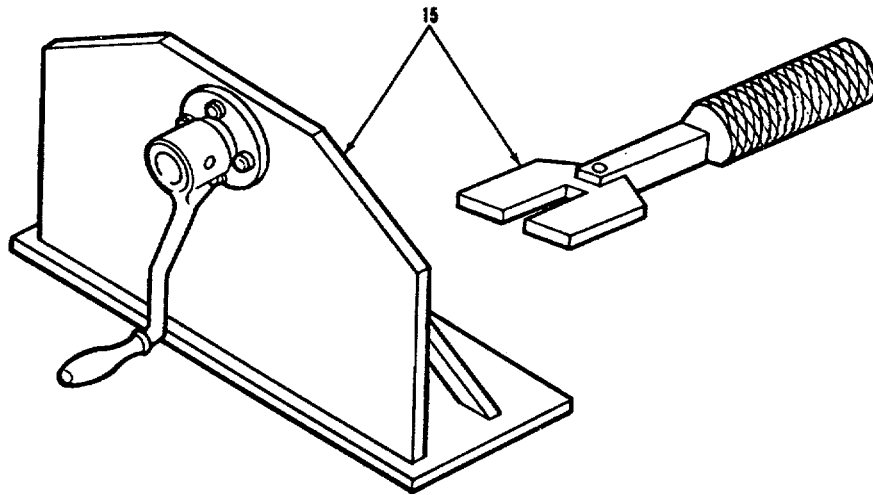

ME 4310-340-24/C-12 ④

Figure C-12. Special tools - (Sheet 4 of 4)

C-34

## Section V. FEDERAL STOCK NUMBER AND REFERENCE NUMBER INDEX

<u>Federal Stock Number</u>	<u>Figure No.</u>	<u>Item No.</u>
1040-970-8426	C-3	7
1040-970-8430	C-10	33
1040-972-2321	C-9	1
1040-974-3740	C-9	8
1040-976-8981	C-9	14
1650-328-3725	C-11	14
1650-605-0252	C-3	17
1650-706-1863	C-11	33
3110-100-6162	C-11	15
3120-009-0551	C-3	20
4310-008-9886	C-4	3
4310-008-9887	C-4	1
4310-008-9888	C-3	2
4310-008-9889	C-5	6
4310-008-9891	C-3	21
4310-008-9892	C-4	8
4310-008-9893	C-7	8
4310-008-9894	C-7	15
4310-008-9896	C-11	28
4310-008-9897	C-11	27
4310-008-9898	C-10	4
4310-102-5564	C-7	11
4310-107-1063	C-8	11
4310-134-4266	C-10	9
4310-134-8909	C-11	1
4310-228-0766	C-1	1
4310-435-4403	C-11	8
4310-781-4659	C-8	19
4310-781-4664	C-8	16
4310-781-4706	C-10	25
4710-009-2170	C-4	10
4710-009-2171	C-6	13
4710-009-2172	C-5	8
4710-009-2173	C-11	23
4730-008-7245	C-5	9
4730-008-7247	C-6	1
4730-008-9872	C-11	24
4730-186-9961	C-4	9
4730-240-5905	C-6	3

<u>Federal Stock Number</u>	<u>Figure No.</u>	<u>Item No.</u>
4730-331-4950	C-3	1
4730-807-2274	C-6	11
4730-855-0698	C-4	2
4820-008-7246	C-3	27
4820-008-9890	C-5	7
4820-008-9895	C-11	5
5305-150-1511	C-3	15
5310-009-9244	C-3	16
5310-053-3551	C-3	8
5310-079-1967	C-6	6
5310-091-1231	C-3	22
5310-141-1795	C-6	8
5310-167-0822	C-B	5
5310-167-0835	C-10	8
5310-515-7449	C-3	25
5310-531-9514	C-3	4
	C-4	5
5310-685-3744	C-11	20
5310-812-3373	C-3	24
	C-6	9
	C-11	40
5315-009-7761	C-8	15
5315-515-8058	C-5	2
5330-008-7913	C-11	2
5330-008-7914	C-11	22
5330-008-7915	C-10	5
5330-008-9194	C-11	18
5330-008-9196	C-11	32
5330-008-9197	C-11	18
5330-008-9226	C-11	16
5330-009-0553	C-10	35
5330-009-0565	C-10	37
5330-009-0566	C-11	4
5340-087-3509	C-11	12
5340-097-7150	C-3	5
5340-150-1191	C-3	26
5340-531-6992	C-3	19
5340-598-0523	C-5	11
5340-805-8518	C-11	9
5360-328-3690	C-3	18
5365-009-3943	C-6	4
6680-009-3569	C-10	34

<u>Reference No.</u>	<u>Mfg. Code</u>	<u>Figure No.</u>	<u>Item No.</u>
AN814-10DL	88044	C-10	28
AN815-4C	88044	C-5	5
AN816-4D	88044	C-6	3
AN822-4C	88044	C-3	1
AN924-4J	88044	C-6	6
AN929-4	88044	C-6	2
AN960C6	88044	C-3	4
		C-4	5
AN960C8	88044	C-11	20
AN960-08	88044	C-5	2
AN960-C416L	88044	C-10	8
AN960-C416	88044	C-3	25
AN960-416	88044	C-6	8
AN060-716	88044	C-8	5
GA7284-1 & GA7284-2	86329	C-11	8
MS122055	96906	C-3	9
		C-8	13
		C-10	3
MS122057	96906	C-3	24
		C-6	9
		C-11	40
		C-7	9
		C-9	16
MS16625-37	BB906	C-11	9
MS20822 -4D	96906	C-4	9
MS20822-6D	96906	C-4	2
MS20823-4C	96906	C-6	14
MS21908-4C	96906	C-6	11
STCP-0810	11828	C-4	6
		C-5	1
STSW-0816	11828	C-11	21
1159-2400	33525	C-10	4
1264-1612	33525	C-11	41
1264-2424	33525	C-10	1
1568-0809	33525	C-3	31
1563-1414	33525	C-3	11
1568-1614	38525	C-3	23
1979-0600	33525	C-3	6
203690	33525	C-10	30
208691	33525	C-10	26
204387	33525	C-3	18

<u>Reference No.</u>	<u>Mfg. Code</u>	<u>Figure No.</u>	<u>Item No.</u>
204388	33525	C-3	17
205039	33525	C-3	19
205493	33525	C-10	31
205494	33525	C-10	32
206517	33525	C-10	29
206527	33525	C-11	37
206844	33525	C-11	14
206845	33525	C-11	13
206852	33525	C-11	15
209984	33525	C-12	
209985	33525	C-12	5
209986	33525	C-12	2
212853	33525	C-11	12
213167	33525	C-9	2
213169	33525	C-9	13
213170	33525	C-9	4
213173	33525	C-10	12
213174	33525	C-10	11
213176	33525	C-7	5
213181	33525	C-7	13
213182	33525	C-7	3
213184	33525	C-10	10
213380	33525	C-8	9
213384	33525	C-8	5
213386	33525	C-8	6
213399	33525	C-9	12
213516	33525	C-3	8
214335	33525	C-10	14
214395	33525	C-7	16
215831	33525	C-7	7
216221	33525	C-3	34
242703	33525	C-11	35
243616	33525	C-3	39
245297	33525	C-11	31
245516	33525	C-9	3
245519	33525	C-7	6
245523	33525	C-10	19
245531	33525	C-7	14
245532	33525	C-7	4
245733	33525	C-11	26

<u>Reference No.</u>	<u>Mfg. Code</u>	<u>Figure No.</u>	<u>Item No.</u>
245734	33525	C-11	30
245808	33525	C-8	8
245821	33525	C-8	1
245835	33525	C-9	9
245836	33525	C-9	10
245837	33525	C-9	11
246763	33525	C-8	7
246876	33525	C-8	2
247064	33525	C-8	3
247067	33525	C-10	15
247069	33525	C-10	13
247237	33525	C-8	15
247364	33525	C-7	12
248231	33525	C-10	24
248232	33525	C-10	20
249336	33525	C-8	18
249337	33525	C-8	17
250606	33525	C-10	18
251718	33525	C-11	16
254693	33525	C-3	20
254694	33525	C-3	22
254695	33525	C-3	16
254799	33525	C-6	12
254804	33525	C-3	15
254845	33525	C-6	4
254854	33525	C-3	5
255111	33525	C-10	21
255112	33525	C-10	22
255113	33525	C-10	23
255121	33525	C-9	5
255122	33525	C-9	6
255123	33525	C-9	7
255134	33525	C-7	21
		C-8	22
255135	33525	C-7	20
		C-8	21
255136	33525	C-7	19
		C-8	20
255201	33525	C-10	36
255207	33525	C-6	1

Reference No.	Mfg. Code	Figure No.	Item No.
255580	33525	C-7	2
256155	33525	C-11	7
258439	33525	C-3	14
258499	33525	C-3	36
258500	33525	C-3	35
258501	33525	C-11	3
258502	33525	C-10	38
27FK-428	56878	C-10	7
27FK-832	56878	C-4	278
		C-5	3
272264	33525	C-9	15
272265	33525	C-9	1
272947	33525	C-8	4
273050	33525	C-7	11
273963	33525	C-10	16
274799	33525	C-8	16
275044	33525	C-8	19
275556	33525	C-8	12
276451	33525	C-11	10
277778	33525	C-11	24
277794	33525	C-7	18
277849	33525	C-6	7
277869	33525	C-3	26
280462	33525	C-3	13
290641	33525	C-3	7
290864	33525	C-10	25
292077	33525	C-11	17
292079	33525	C-7	17
292084	33525	C-10	4
292085	33525	C-7	8
292932	33525	C-10	34
5008-125	79136	C-11	29
5110-0800	33525	C-3	30
5206-6324	33525	C-11	36
5206-6524	33525	C-11	34
523632	80201	C-11	32
523633	80201	C-11	18
5292-0622	33525	C-3	3
5292-1108	33525	C-3	10

<u>Reference No.</u>	<u>Mfg. Code</u>	<u>Figure No.</u>	<u>Item No.</u>
5337-0400	33525	C-3	12
5475-0400	33525	C-11	38
5652-2400	33525	C-10	41
5729-0012	33525	C- 11	11
5729-0014	33525	C-10	37
5729-0040	33525	C-10	17
5729- 0137	33525	C-10	5
5729-0149	33525	C-11	2
5729-0904	33525	C-11	4
5729-0906	33525	C-10	35
5729-0908	33525	C-11	22
5729-0910	33525	C-10	27
5729-0912	33525	C-7	1
		C-8	23
5811-0402	33525	C-3	33
5811-0403	33525	C-11	39
5833-1014	33525	C-10	2
5833-1034	33525	C-8	14
5833-1614	33525	C-9	17
5833-1640	33525	C-7	10
5833-1656	33525	C-6	10
5862-0402	33525	C-3	3?
6052-0800	33525	C-11	19
6347-0020	33525	C-8	10
754-10-2-6-HT	83903	C-3	29
		C-5	4
		C-4	4
754-14-2-8	83903	C-5	11
804419	33525	C-12	3
804420	33525	C-12	4
804421	33525	C-12	7
804422	33525	C-12	11
804423	33525	C-12	10
804424	33525	C-12	8
804425	33525	C-12	9
804426	33525	C-12	12
841727	33525	C-10	33
842294	33525	C-9	14
842565	33525	C-8	11



<u>Reference No.</u>	<u>Mfg. Code</u>	<u>Figure No.</u>	<u>Item No.</u>
843740	33525	C-5	9
843913	33525	C-7	15
843914	33525	C-11	6
843916	33525	C-11	27
843956	33525	C-11	23
844192	33525	C-3	38
871981	33525	C-12	1
872371	33525	C-11	33
873732	33525	C-9	8
874907	33525	C-10	9
874908	33525	C-10	6
875551	33525	C-4	8
876005	33525	C-3	21
876009	33525	C-11	28
876029-4500	33525	C-5	7
876031	33525	C-5	8
876034	33525	C-3	27
876035	33525	C-11	5
876700	33525	C-12	13
876701	33525	C-12	14
890854	33525	C-12	15
894780	33525	C-1	1
894791	33525	C-2	1
894794	33525	C-11	1
894799	33525	C-11	25
894804	33525	C-4	3
894805	33525	C-4	1
894808	33525	C-6	13
894810	33525	C-3	2
894819	33525	C-5	6
894821	33525	C-4	10
896060	33525	C-10	39

INDEX

	Paragraph	Page		Paragraph	Page
<b>A</b>					
Aftercooler:			Discharge Elbow Bracket:		
Installation .....	3-14 <i>b</i>	3-4	Installation .....	3-20 <i>b</i>	3-6
Removal .....	3-14 <i>a</i>	3-4	Removal .....	3-20 <i>a</i>	3-6
Aftercooler Tube:			Drain Tube Assembly:		
Installation .....	3-11 <i>b</i>	3-4	Installation.....	3-7 <i>b</i>	3-3
Removal .....	3-11 <i>a</i>	3-4	Removal .....	3-7 <i>a</i>	3-3
Air Fittings:			<b>E</b>		
Installation .....	3-28 <i>b</i>	3-7	Elbow, Discharge:		
Removal .....	3-28 <i>a</i>	3-7	Installation .....	3-19 <i>b</i>	3-6
Air Inlet Fittings:			Removal .....	3-19 <i>a</i>	3-6
Installation .....	2-12 <i>b</i>	2-4	<b>F</b>		
Removal .....	2-12 <i>a</i>	2-4	Fan:		
<b>B</b>			Installation.....	3-6 <i>b</i>	3-3
Bracket, Discharge Elbow:			Removal .....	3-6 <i>a</i>	3-3
Installation .....	3-20 <i>b</i>	3-6	Fan Guard:		
Removal .....	3-20 <i>a</i>	3-6	Installation.....	3-5 <i>b</i>	3-2
Bracket., Fan Guard:			Removal .....	3-5 <i>a</i>	3-2
Installation .....	3-15 <i>b</i>	3-5	Fan Guard Bracket:		
Removal .....	3-15 <i>a</i>	3-5	Installation .....	3-15 <i>b</i>	3-5
<b>C</b>			Removal .....	3-15 <i>a</i>	3-5
Cap, Oil Drain Tube			Fan Spring:		
Installation .....	2-10 <i>b</i>	2-4	Installation .....	3-6 <i>b</i>	3-3
Removal .....	2-10 <i>a</i>	2-4	Removal .....	3-6 <i>a</i>	3-3
Chain, Oil Drain Tube Cap:			First Stage Cooler:		
Installation .....	2-11 <i>a</i>	2-4	Installation .....	3-10 <i>b</i>	3-4
Removal .....	2-11 <i>b</i>	2-4	Removal .....	3-10 <i>a</i>	3-4
Chart, Maintenance Allocation .....	B-1	b-1	Fittings, Air and Hydraulic:		
Check Valve:			Installation .....	3-28 <i>b</i>	3-7
Installation .....	3-21 <i>b</i>	3-6	Removal .....	3-28 <i>a</i>	3-7
Removal .....	3-21 <i>a</i>	3-6	Fitting Air Inlet:		
Check Valve Tee:			Installation .....	2-12 <i>b</i>	2-4
Installation .....	3-22 <i>b</i>	3-6	Removal .....	2-12 <i>a</i>	2-4
Removal .....	3-22 <i>a</i>	3-6	Fitting, Restrictor, Fourth Stage:		
Cooler, First Stage:			Installation.....	3-18 <i>b</i>	3-6
Installation .....	3-10 <i>b</i>	3-4	Removal .....	3-18 <i>a</i>	3-6
Removal .....	3-10 <i>a</i>	3-4	Forma and records.....	1-2	1-1
Cooler, Second Stage:			Fourth stage relief valve:		
Installation .....	3-9 <i>b</i>	3-3	Installation.....	3-12 <i>b</i>	3-4
Removal .....	3-9 <i>a</i>	3-3	Removal .....	3-12 <i>a</i>	3-4
Cooler, Third Stage:			Fourth Stage Relief Valve Tube:		
Installation .....	3-8 <i>b</i>	3-3	Installation.....	3-13 <i>b</i>	3-4
Removal .....	3-8 <i>a</i>	3-3	Removal .....	3-13 <i>a</i>	3-13 <i>a</i>
<b>D</b>			Fourth Stage Restrictor Fitting:		
Data, Tabulated .....	1-5	1-3	Installation .....	3-18 <i>b</i>	3-6
Description and Data:			Removal .....	3-18 <i>a</i>	3-6
Description .....	1-4	1-1	Front Oil Seal:		
Tabulated data .....	1-5	1-3	Installation .....	3-27 <i>b</i>	3-7
Dipstick Oil Level:			Removal .....	3-27 <i>a</i>	3-7
Installation .....	2-13 <i>b</i>	2-4	<b>G</b>		
Removal .....	2-13 <i>a</i>	2-4	Guard, Fan:		
Direct support repair parse .....	3-1	3-1	Installation .....	3-5 <i>b</i>	3-2
Direct support special tools .....	3-2	3-1	Removal .....	3-5 <i>a</i>	3-2
Discharge Elbow:			<b>H</b>		
Installation .....	3-19 <i>b</i>	3-6	Hydraulic Fittings:		
Removal .....	3-19 <i>a</i>	3-6	Installation .....	3-28 <i>b</i>	3-7
			Removal .....	3-28 <i>a</i>	3-7

	Paragraph	Page		Paragraph	Page
Indexes, Publications .....	A-1	A-1	Repair parts, direct support and general support .....	3-1	3-
Inspecting and Servicing Instructions Organizational .....	2-2	2-1	Reporting of errors .....	1-3	1-
<b>M</b>			<b>S</b>		
Maintenance Allocation Chart .....	B-1	B-1	Screen, oil pickup: Installation .....	3-24b	3-
Maintenance Functions, Organizational. Manifold, Oil Fill and Dipstick: Installation .....	2-6	2-1	Removal .....	3-24a	3-
Removal .....	3-25b	3-7	Seal, Oil, Front: Installation .....	3-27b	3-
Removal .....	3-25a	3-7	Removal .....	3-27a	3-
<b>O</b>			Seal, Oil, Rear: Installation .....	3-26b	3-
Oil Drain Tube Cap: Installation .....	2-10b	2-4	Removal .....	3-26a	3-
Removal .....	2-10a	2-4	Second Stage Cooler: Installation .....	3-9b	3-
Oil Drain Tube Cap Chain: Installation .....	2-11b	2-4	Removal .....	3-9a	3-
Removal .....	2-11a	2-4	Second Stage Relief Valve: Installation .....	3-17b	3-
Oil Fill and Dipstick Manifold: Installation .....	3-25b	3-7	Removal .....	3-17a	3-
Removal .....	3-25a	3-7	Special Tools, Direct Support and General Support .....	3-2	3-
Oil Fill Plug and Packing: Installation .....	2-14b	2-4	Special Tools, Organizational .....	3-4	3-
Removal .....	2-14a	2-4	Spring, Fan: Installation .....	3-6b	3-
Oil Inlet Tube: Installation .....	3-23b	3-6	Removal .....	3-6a	3-
Removal .....	3-23a	3-6	<b>T</b>		
Oil Level Dip stick and Packing: Installation .....	2-13b	2-4	Tabulated Data .....	1-5	1-
Removal .....	2-13a	2-4	Tee, Check Valve: Installation .....	3-22b	3-
Oil Pickup Screen: Installation .....	3-24b	3-7	Removal .....	3-22a	3-
Removal .....	3-24a	3-6	Third Stage Cooler: Installation .....	3-8b	3-
Organizational Inspecting and Servicing Instructions.....	2-2	2-1	Removal .....	3-8a	3-
Organizational Maintenance Functions .	2-6	2-1	Third Stage Relief Valve: Installation .....	3-16b	3-
Organizational Preventive Maintenance Procedures .....	2-7	2-1	Removal .....	3-16a	3-
Organizational Repair Parts .....	2-3	2-1	Troubleshooting, Direct Support .....	3-3	3-
Organizational Special Tools .....	2-4	2-1	Troubleshooting, Organizational .....	2-8	2-
<b>P</b>			Tube, Aftercooler: Installation .....	3-11b	3-
Packing, Oil Fill Plug: Installation .....	2-14b	2-4	Removal .....	3-11a	3-
Removal .....	2-14a	2-4	Tube Assembly Oil Drain: Installation .....	3-7b	3-
Packing, Oil Level Dipstick: Installation .....	2-13b	2-4	Removal .....	3-7a	3-
Removal .....	2-13a	2-4	Tube, Fourth Stage Relief Valve: Installation .....	3-13b	3-
Parts, Repair, Direct Support and General Support .....	3-1	3-1	Removal .....	3-13a	3-
Parts, repair organizational .....	2-3	2-1	Tube, Oil Inlet: Installation .....	3-23b	3-
Plug, oil fill: Installation .....	2-14b	2-4	Removal .....	3-23a	3-
Removal .....	2-14a	2-4	<b>V</b>		
Preventive maintenance procedures, organizational .....	2-7	2-1	Valve, Check: Installation .....	3-31b	3-
Publication indexes .....	A-1	A-1	Removal .....	3-21a	3-
Publications, references .....	A-2	A-1	Valve, Relief, Fourth Stage: Installation .....	3-12b	3-
<b>R</b>			Removal .....	3-12a	3-
Rear oil seal: Installation .....	3-26b	3-7	Valve, relief, second stage: Installation .....	3-17b	3-
Removal .....	3-26a	3-7	Removal .....	3-17a	3-
Reference publications .....	A-2	A-1	Valve, Relief, third stage: Installation .....	3-16b	3-
			Removal .....	3-16a	3-

By Order of the Secretary of the Army:

CREIGHTON W. ABRAMS  
*General, United States Army*  
*Chief of Staff*

Official:

VERNE L. BOWERS  
*Major General, United States Army*  
*The Adjutant General*

DISTRIBUTION:

To be distributed in accordance with DA Form 12-37. (qty rqr block No. 214).  
Organizational maintenance requirements for Tank, Combat. Full Tracked, 152MM Gun Launcher  
M60A1 E2.

\*U.S. GOVERNMENT PRINTING OFFICE: 1991 - 281-486/42582

